

# Qucs

---

A Tutorial  
BJT Modeling and Verification

Thierry Scordilis

---

Copyright © 2005 Thierry Scordilis <thierry.scordilis@free.fr>

Permission is granted to copy, distribute and/or modify this document under the terms of the GNU Free Documentation License, Version 1.1 or any later version published by the Free Software Foundation. A copy of the license is included in the section entitled "GNU Free Documentation License".

## warning

*This chapter will describe an RF design issue using QUCS. The author assume that the basic manipulation of qucs is known. You will find herein mainly a MacOSX description that is close to a linux or unices architecture.*

## choice of transistor

The choice has been made to choose among the Philips RF wideband transistor library. These components are easy to find, with resonnable prices.

This list could be found at <http://www.semiconductors.philips.com/>.

A resume of these transistors can be found in the figure 1

I will not discuss herein, the reason <sup>1</sup> why of the final choice, but the *BFG425w* is the candidate. It offers high gain, with low figure noise ( if LNA consideration ) high transistion frequency ( 25 GHz ), its emitter is thermal lead, low feedback capacitance. This device could be used in RF front end, analog or digital cellular, radar detectors, pagers, SATV, oscillators. It is in a SOT343R package suitable for small integration.

The maximum acheivable gain is 20 dB with 25 mA,  $V_{ce} = 2$  V at 2 GHz and  $25^{\circ}C$ . The third order intercept point in these conditions is typically *22dBm*.

These parameter should be compatible with our need. Here are the spice parameter of the device.

```
.SUBCKT BFG425W 1 2 3
L1  2 5 1.1E-09
L2  1 4 1.1E-09
L3  3 6 0.25E-09
Ccb 4 5 2.0E-15
Cbe 5 6 80.0E-15
Cce 4 6 80.0E-15
Cbpb 5 7 1.45E-13
Cbpc 4 8 1.45E-13
Rsb1 6 7 25
Rsb2 6 8 19
Q1 4 5 6 6 NPN

.MODEL NPN NPN
+ IS = 4.717E-17 + BF = 145 + NF = 0.9934
```

<sup>1</sup>regarding current,  $F_t$ ,  $V_{ce}$ , power dissipation, etc ...

**Selection results for RF wideband transistors**

Go to the interactive version of this Selection Guide.  
 Download in MS-Excel sheet (right-click and choose Save Target As...)

**80 RESULTS SHOWN.**

Type number	PACKAGE	Category	POLARITY	$P_{out}$ (mW)	$I_c$ (mA)	$f_r$ (GHz)	VCEO max (V)	$\beta$ (min)	$\beta$ (max)	$G_{m, dB}$	Frequency (MHz)	NOISE FLOOR (dB)	$G_{m, dB}$	$\beta$ (min)	$\beta$ (max)	$V_{CE}$ (V)	$\theta_{JC}$ (°C)	ITD (dBm)	Socket	$V_{0.2}$ (mV)	$P_1$ (mW)	$V_0$ (mV)	Gain @900 MHz (dB)	Gain @1.5 GHz (dB)	System Freq. (MHz)
BFG10	SOT1438	Transistor wideband NPN up to 3.5 GHz	NPN	250.0	250.0	8.0	1900.0	1900	7.0																
BFG10A	SOT1438	Transistor wideband NPN up to 3.5 GHz	NPN	250.0	250.0	8.0	1900.0	1900	7.0																
BFG10W/X	SOT1438	Transistor wideband NPN up to 3.5 GHz	NPN	250.0	250.0	8.0	1900.0	1900	7.0																
BFG135	SOT223	Transistor wideband NPN up to 8 GHz	NPN	1000.0	100.0	8.0	10.0	500	18.0																
BFG198	SOT223	Transistor wideband NPN up to 8 GHz	NPN	1000.0	100.0	8.0	10.0	500	18.0																
BFG21W	SOT343R	Transistor wideband NPN up to 25 GHz	NPN	32.0	6.5	5.0	5.0	1000.0	18.0	1.8															
BFG25A/X	SOT1438	Transistor wideband NPN up to 6 GHz	NPN	500.0	100.0	15.0	500.0	500	16.0																
BFG25AW/X	SOT1438	Transistor wideband NPN up to 6 GHz	NPN	500.0	100.0	15.0	500.0	500	16.0																
BFG31	SOT223	Transistor wideband PNP up to 6 GHz	PNP	1000.0	100.0	4.0	18.0	15.0	15.0																
BFG35	SOT223	Transistor wideband NPN up to 6 GHz	NPN	16.0	3.6	17.0			1.6																
BFG401W																									
BFG410W	SOT343R	Transistor wideband NPN up to 25 GHz	NPN	54.0	12.0	22.0	4.5	900	1.2																
BFG425W																									
BFG480W																									
BFG505	SOT1438		NPN	150.0	18.0			900.0	20.0																
BFG505A/X	SOT1438		NPN	150.0	18.0			900.0	20.0																
BFG505W/X	SOT1438		NPN	150.0	18.0			900.0	20.0																
BFG520																									
BFG520A/X	SOT1438																								
BFG520A/R																									
BFG520W	SOT343R																								
BFG520W/X	SOT343R	Transistor wideband NPN up to 10 GHz		500.0			900.0																		
BFG540	SOT1438																								
BFG540A/X	SOT1438																								
BFG540A/R	SOT1438																								
BFG540W																									
BFG540W/X	SOT343R			500.0			900.0																		

Figure 1: transistor table from philips semiconductor

```
+ VAF = 31.12 + IKF = 0.304 + ISE = 3.002E-13
+ NE = 3 + BR = 11.37 + NR = 0.985
+ VAR = 1.874 + IKR = 0.121 + ISC = 4.848E-16
+ NC = 1.546 + RB = 14.41 + IRB = 0
+ RBM = 6.175 + RE = 0.1779 + RC = 1.780
+ CJE = 3.109E-13 + VJE = 0.9 + MJE = 0.3456
+ CJC = 1.377E-13 + VJC = 0.5569 + MJC = 0.2079
+ CJS = 6.675E-13 + VJS = 0.4183 + MJS = 0.2391
+ XCJC = 0.5 + TR = 0.0 + TF = 4.122E-12
+ XTF = 68.2 + VTF = 2.004 + ITF = 1.525
+ PTF = 0 + FC = 0.5501 + EG = 1.11
+ XTI = 3 + XTB = 1.5
.ENDS
```

Since the model used in SPICE and in QUCS rely on a gummel-poon modelisation, and since the level of modelisation is the same, some quite direct conversion could be used to create the library for QUCS.

To use directly this file, you will need to store the file in an other directory from the project one ( a small bug taken into account ). Then it should work but some there are still some issues on the parameters themselves, This is the reason why we will proceed in an other way.

The data sheet could be found on the philips web site.

NPN 25 GHz wideband transistor

BFG425W

SPICE parameters for the BFG425W die

SEQUENCE No.	PARAMETER	VALUE	UNIT
1	IS	47.17	aA
2	BF	145.0	-
3	NF	0.993	-
4	VAF	31.12	V
5	IKF	304.0	mA
6	ISE	300.2	fA
7	NE	3.000	-
8	BR	11.37	-
9	NR	0.985	-
10	VAR	1.874	V
11	IKR	0.121	A
12	ISC	484.8	aA
13	NC	1.546	-
14	RB	14.41	$\Omega$
15	IRB	0.000	A
16	RBM	6.175	$\Omega$
17	RE	177.9	m $\Omega$
18	RC	1.780	$\Omega$
19 <sup>(1)</sup>	XTB	1.500	-
20 <sup>(1)</sup>	EG	1.110	eV
21 <sup>(1)</sup>	XTI	3.000	-
22	CJE	310.9	fF
23	VJE	900.0	mV
24	MJE	0.346	-
25	TF	4.122	ps
26	XTF	68.20	-
27	VTF	2.004	V
28	ITF	1.525	A
29	PTF	0.000	deg
30	CJC	137.7	fF
31	VJC	556.9	mV
32	MJC	0.207	-
33	XCJC	0.500	-
34 <sup>(1)</sup>	TR	0.000	ns
35 <sup>(1)</sup>	CJS	667.5	fF
36 <sup>(1)</sup>	VJS	418.3	mV
37 <sup>(1)</sup>	MJS	0.239	-
38	FC	0.550	-

SEQUENCE No.	PARAMETER	VALUE	UNIT
39 <sup>(2)(3)</sup>	C <sub>bp</sub>	145	fF
40 <sup>(2)</sup>	R <sub>sb1</sub>	25	$\Omega$
41 <sup>(3)</sup>	R <sub>sb2</sub>	19	$\Omega$

Notes

1. These parameters have not been extracted, the default values are shown.
2. Bonding pad capacity C<sub>bp</sub> in series with substrate resistance R<sub>sb1</sub> between B' and E'.
3. Bonding pad capacity C<sub>bp</sub> in series with substrate resistance R<sub>sb2</sub> between C' and E'.

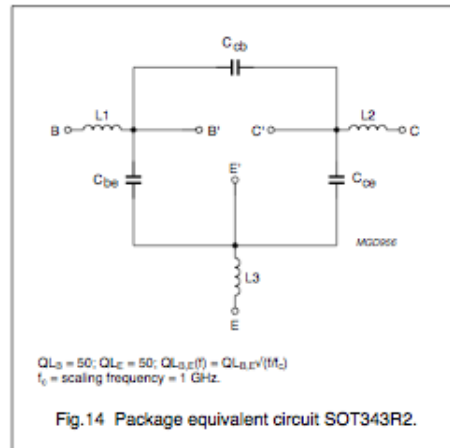

Fig.14 Package equivalent circuit SOT343R2.

List of components (see Fig.14)

DESIGNATION	VALUE	UNIT
C <sub>ce</sub>	80	fF
C <sub>cb</sub>	2	fF
C <sub>be</sub>	80	fF
L1	1.1	nH
L2	1.1	nH
L3 (note 1)	0.25	nH

Note

1. External emitter inductance to be added separately due to the influence of the printed-circuit board.

Figure 2: spice parameter extract from philips data sheet

## library creation

Remember that when creating a device, it is almost always mandatory to read of have a look at on how the model is done is the technical documentation. It is very to understand the limitation, and how we can correct some data if needed. The mian pity is that a lot of commercial software are quite obscure on the real model they use and their limitation ; QUCS is quite exceptionnal on this point this the complete modeling is explain theoretically in a special technical paper.

In order to conduct these test, we need to create a model of our component. To perform this you should create the file that contain all the libraries, this file is stored under

```
/usr/local/share/qucs/library/philips_RF_widebande_npn.lib
```

You can edit this file with vi. You need to add the following line :

```
<Qucs Library 0.0.7 "philips RF wideBand">

<Component BFG425W>
  <Description>
    RF wideband NPN 25GHz
    2V, 25mA, 20dB , 2000MHz
    Manufacturer: Philips Inc.
    NPN complement: BFG425W
    -----
    based on spice parameter from philips
    -----
    sept 2005  thierry
  </Description>
  <Model>
<_BJT T_BFG425W_ 1 480 280 8 -26 0 0 "npn" 1 "47.17e-10"
1 "1" 1 "1" 1 "0.304" 1 "0.121" 1 "31.12" 1 "1.874" 0
"300.2e-15" 1 "3" 1 "484.8e-10" 1 "1.546" 1 "145" 1 "11.37"
1 "6.175" 1 "0" 1 "1.78" 1 "0177.9e-3" 1 "014.41" 1 "310.9e-15"
1 "0.900" 1 "0.346" 1 "137.7e-15" 1 "0.5569" 1 "0.207" 1 "0.500"
1 "667.5e-15" 1 "0.4183" 1 "0.239" 1 "0.550" 1 "4.122e-12" 1
"68.2" 1 "2.004" 1 "1.525" 1 "0.0" 1 "26.85" 1 "0.0" 0 "1.0" 0
"1.0" 0 "0.0" 0 "1.0" 0 "1.0" 0 "0.0" 0>
  </Model>
</Component>
```

You can replace the 1 by 0, this will remove the visible checkbox, the fact to place a 1 first enable the user to change and or view the parameters that are being used. A trick to provide all the required syntax is to fill a NPN into the schematics, perform a copy on the device, you should then have the model in the clipboard, just paste into to file and add the description and the markup language boundaries. The syntaxe is explained in the help at the topic *description of the qucs file formats*. Then the device is visible in the Component Library Tool as mentionned in figure 3.

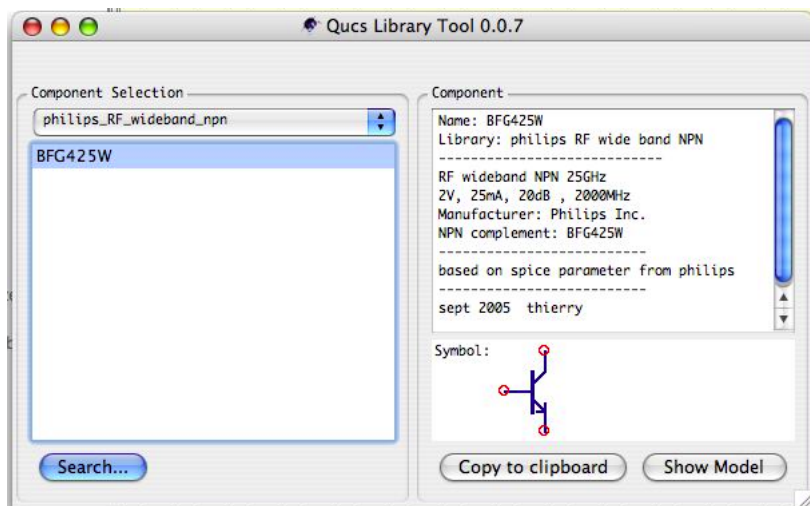

Figure 3: QUCS Component Library showing the new component

By doing this you had the possibility to reuse the device as much as you want, and you can debug devices in a more easy way.

**Warning** : in this section we have only describe the die of the device, for the parasitic from the package, we will be obliged to describe this circuit, but later on.

## device library verification

The first step, before using the device in a application, is to verify the model you use. Especially since this model has been created by the user. In order to proceed, you need to rely on exact data : that is to say the official datasheet.

it this step, you will need to create a project especially for the device verification. It is good to keep a trace of the device verification, since you could have different use of this device, so it is good to be able to redo some simulation around the model itself.

The created project should look that the figure 4.

project name : model\_verif\_bfg425w  
project location : \$HOME/.qucs/

For the validation we will need to use a specific bias of the device :  $I_c$  should be  $25mA$ , therefore  $I_b$  should be  $300\mu A$



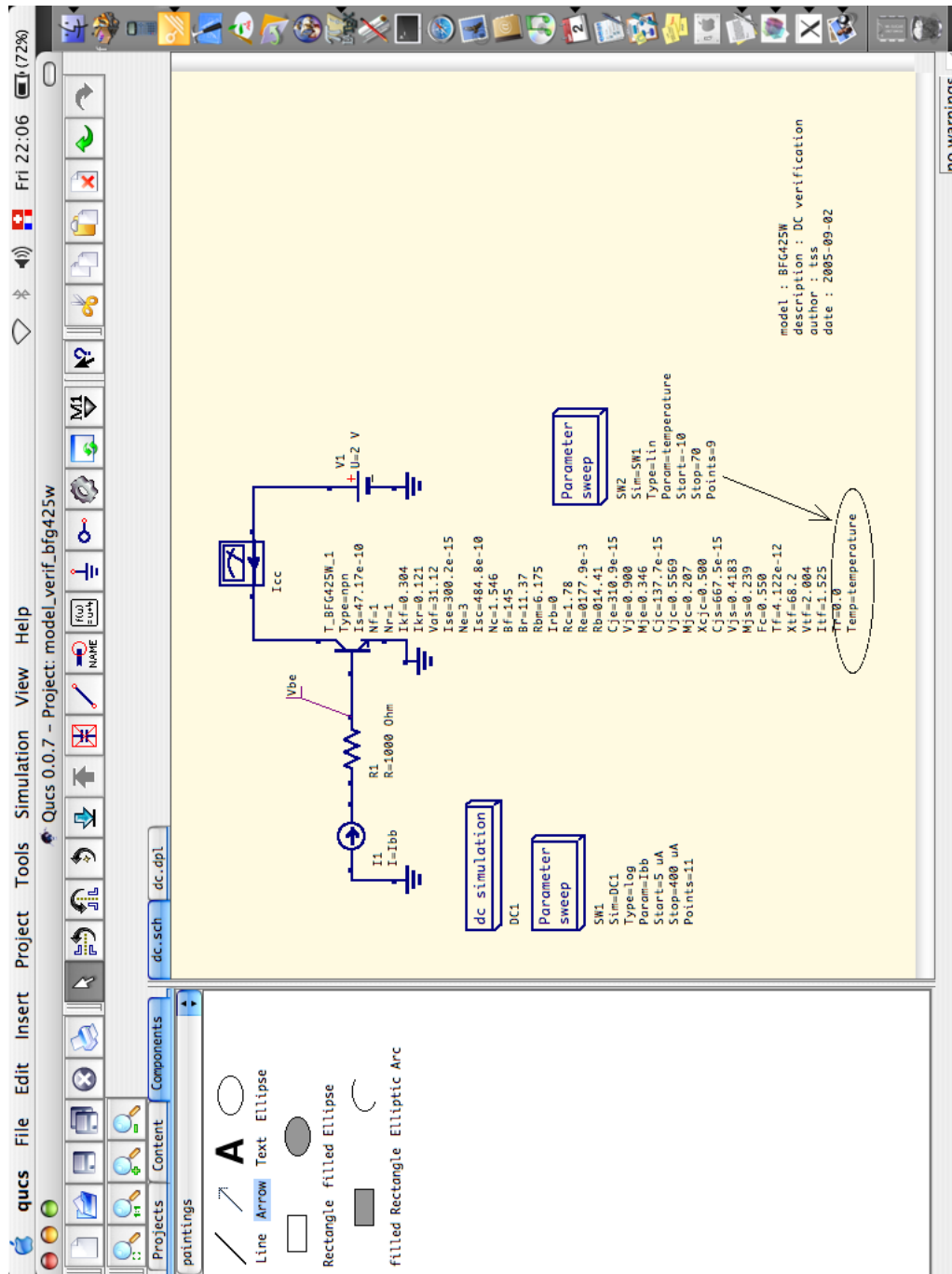

Figure 4: QUCS project for model verification

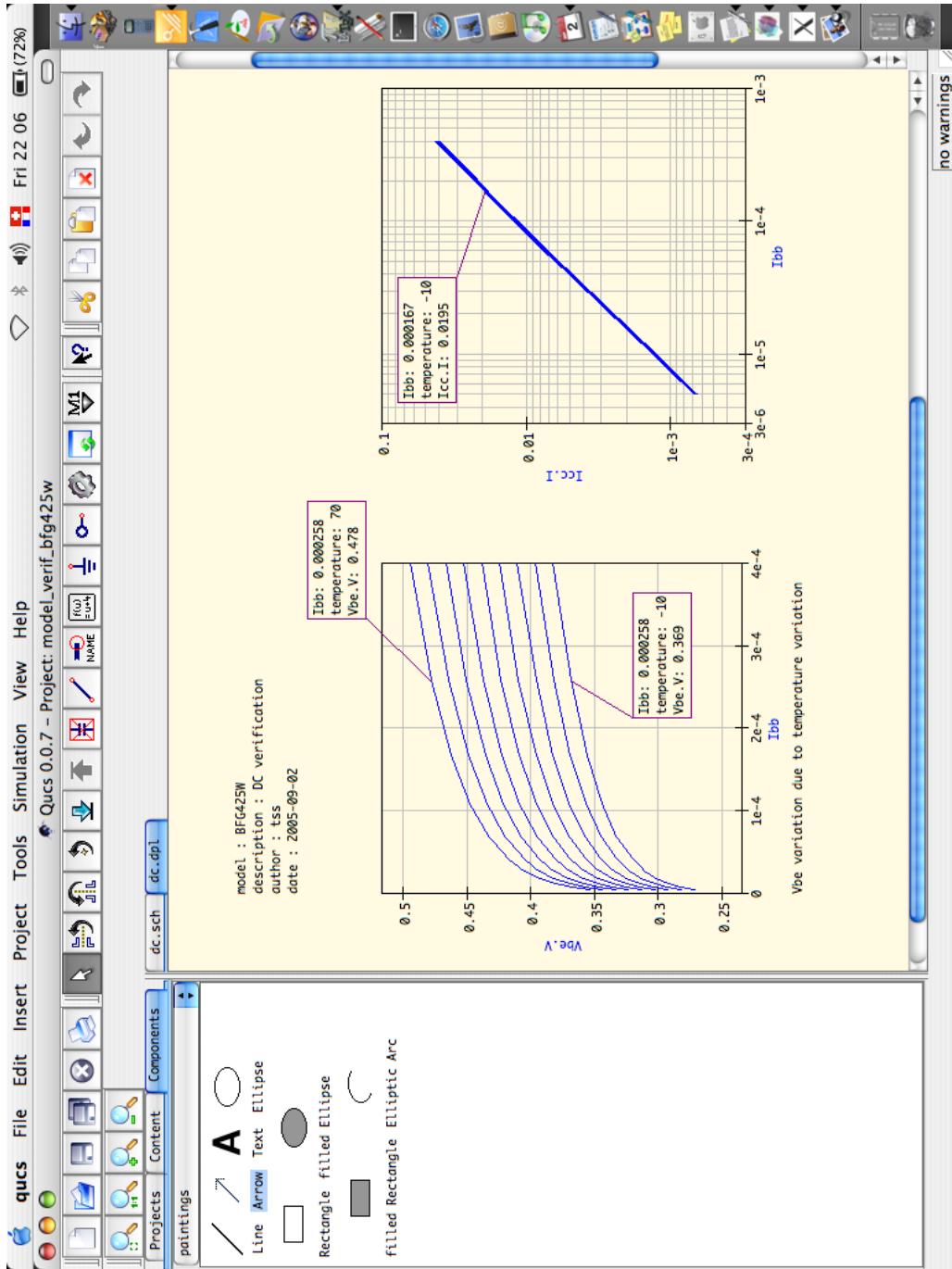

Figure 5: DC validation and temperature

## parasitic description of the package

In order to simulate properly the device, you need to use the correct package, that is to say the *SOT343R* in our case, as mentioned on the philips web site (see fig. 6).

Eventhough the device has two emitters, the model used has only one emitter. The parasitics of this model are shown in the spice netlist described in the choice of the transistor and reproduced in a schematic (see fig. 8). These parameters are always critical to extract, either you have the knowledge to do it or then you should rely on the piece of information given by the device manufacturer. It is also very difficult to figure out what has to be changed in such a description of the device. Some fittings have been performed using 3D electromagnetic software in the time domain based on MOM methods to verify these parameters.

Philips's fifth generation double poly silicon wideband technology uses a steep emitter doped profile resulting in transition frequencies over 20 GHz, and with poly base contacts a low base resistance is obtained. Via the buried layer, the collector contact is brought out at the top of the die. The substrate is connected directly to the emitter package lead, resulting in improved thermal performance (see fig 7).

From this schematic you can edit the symbol that could be used in the next simulation file. To proceed type *F3* or edit circuit symbol from the file menu. Simply draw a npn transistor and come back to the schematic by re-pressing *F3*.

Plastic surface mounted package; reverse pinning; 4 leads

SOT343R

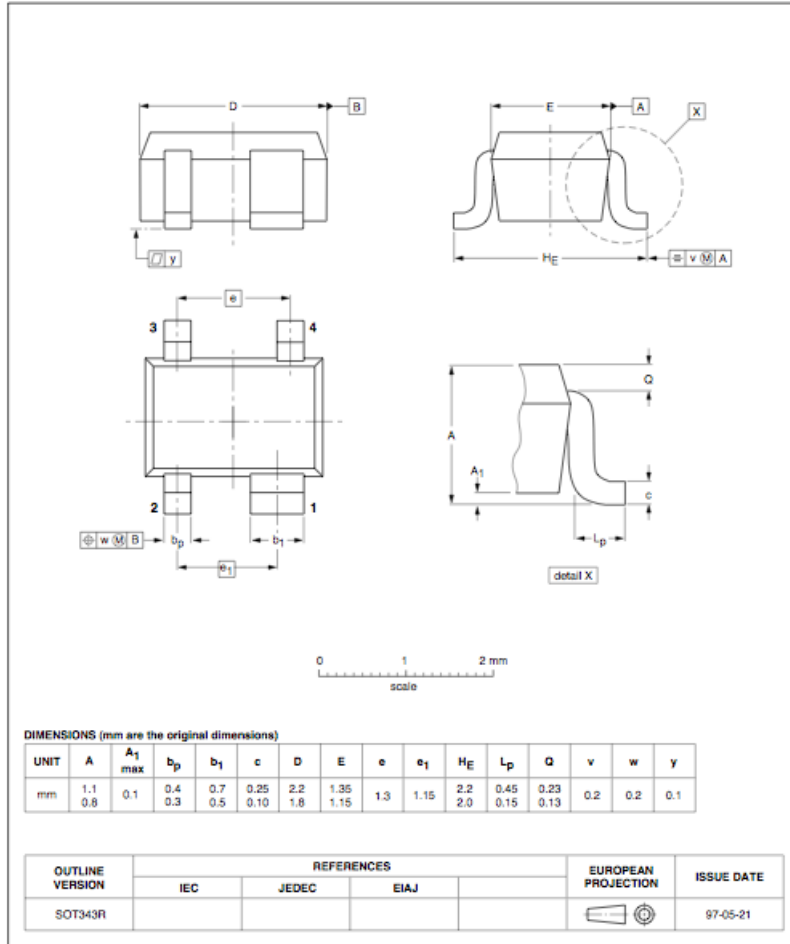

Figure 6: SOT343R package description

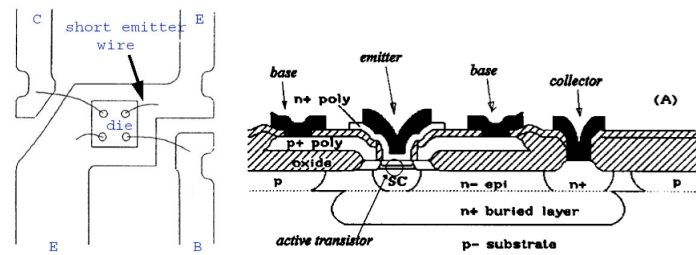

Figure 7: die connection of the fifth generation transistor from philips

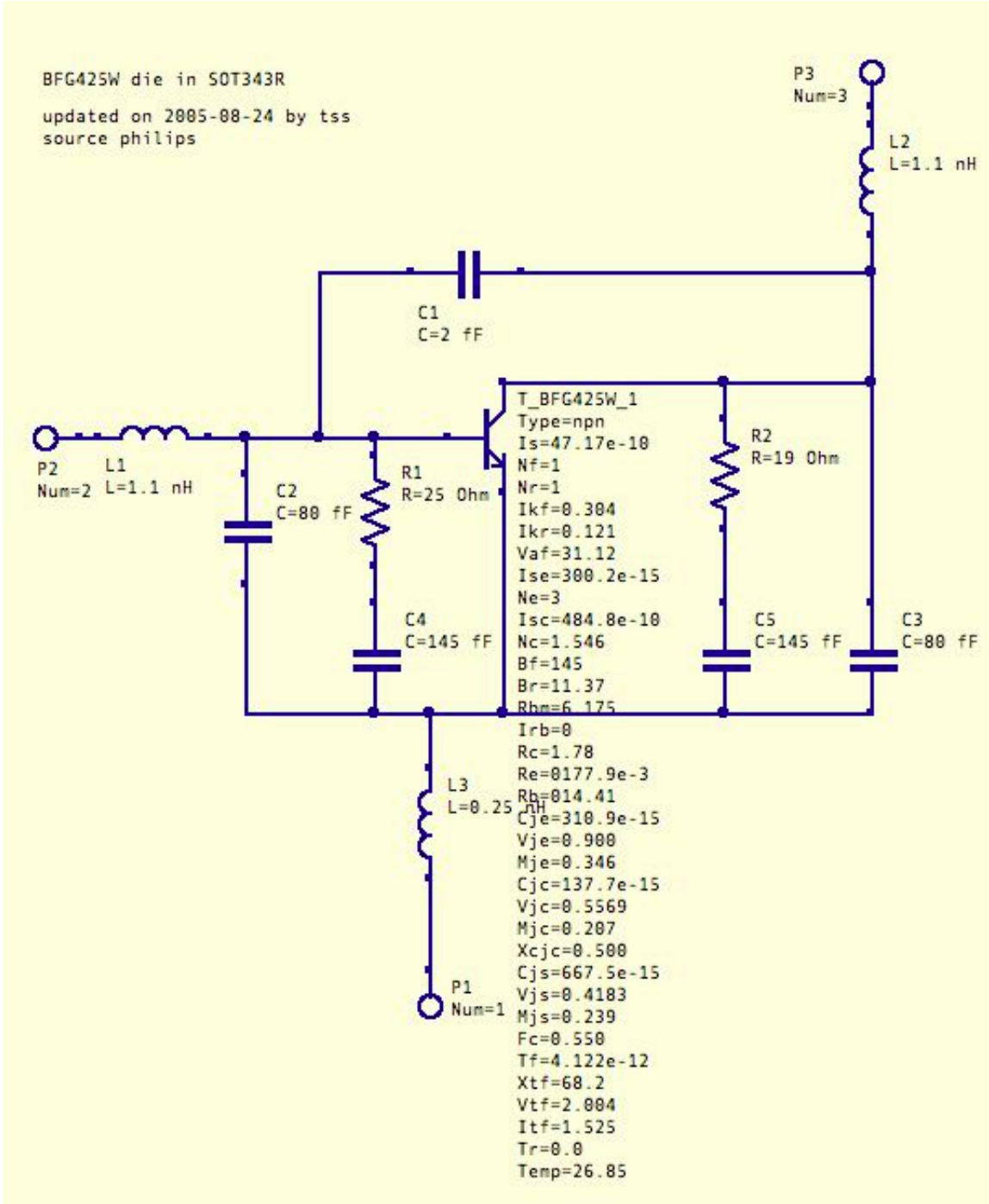

Figure 8: *bfg425W* in *sot343R* package description

## small signal S parameter verification

In this section we will need to redraw a new schematics using the model we have created, plus some extra components to place the measurements ports <sup>2</sup>.

You should have a schematics like the one mentioned in fig9.

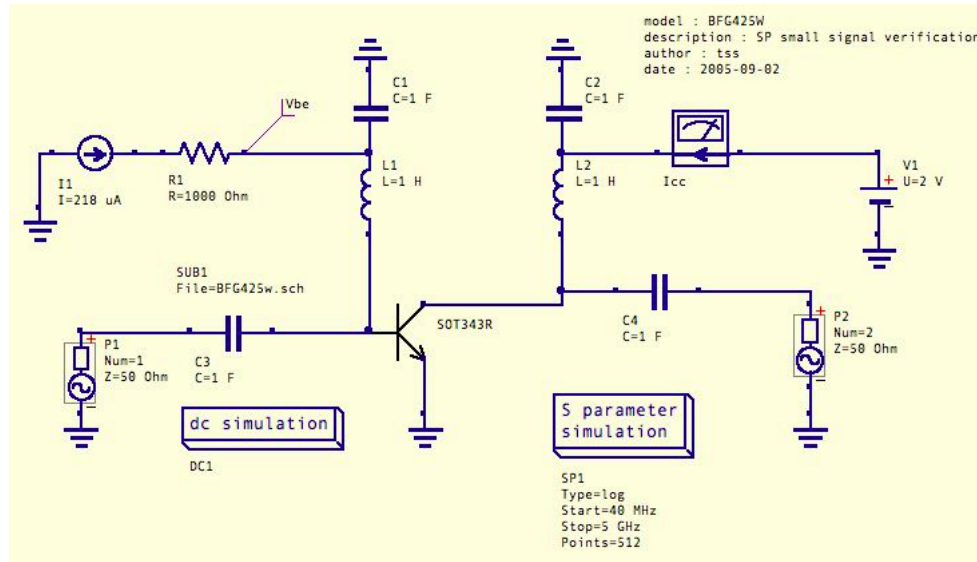

Figure 9: schematics used for S parameters simulation

The components used to verify the model could be strange ( inductor of  $1H$  and capacitor of  $1F$  ) It is normal since we need to have a very wide band response on the circuit, and since we want to characterize only the active device, and compare with the datasheet. An other way is to use DC bloc or DC feed or bias Tee to provide the power supply to the component. This is the right way to do it.

you should then create a display to visualize the S parameters : generally  $s_{11}$  and  $s_{22}$  are in the smith and  $s_{12}$  and  $s_{21}$  are in polar

We have now to compare these results with the measured parameters from philips :

```
! Filename: 225bfg425.001
! BFG425W Field C1
! V1=8.667E-001V,V2=2.000E+000V, I1=3.585E-004A, I2=2.496E-002A
!
!           S11           S21           S12           S22
!Freq(GHz)  Mag      Ang      Mag      Ang      Mag      Ang      Mag      Ang
-----
```

<sup>2</sup>We will another method when we will use the device in a real project

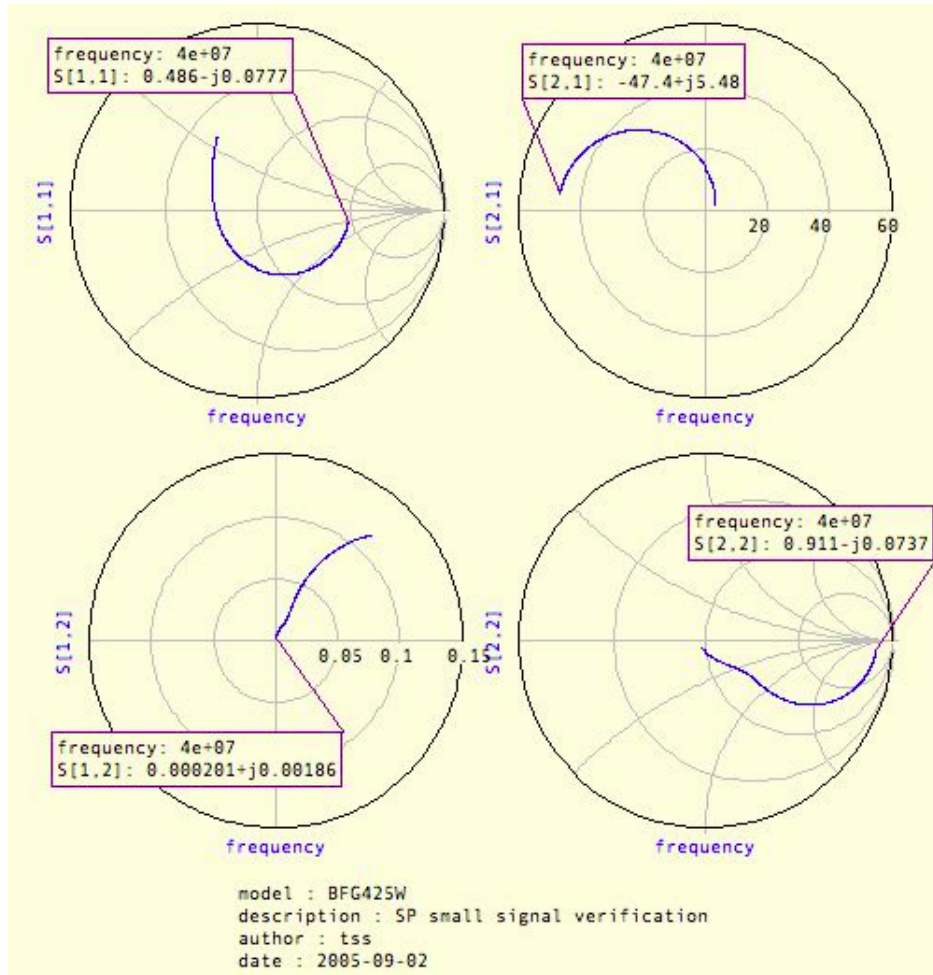

Figure 10: S parameters simulation for model verification



# GHz	S	MA	R	50					
0.040	0.325	-8.696	38.472	173.381	0.002	71.865	0.923	-3.072	
0.100	0.331	-23.004	37.457	164.549	0.005	83.280	0.915	-9.551	
0.200	0.315	-44.455	34.771	150.487	0.008	75.947	0.863	-18.965	
0.300	0.296	-63.008	31.364	138.811	0.012	71.608	0.794	-26.449	
0.400	0.278	-79.654	27.951	128.829	0.015	68.186	0.725	-32.076	
0.500	0.265	-94.339	24.856	120.248	0.017	65.974	0.664	-36.332	
0.600	0.254	-106.508	22.159	113.362	0.020	64.514	0.613	-39.533	
0.700	0.246	-116.820	19.885	107.530	0.022	63.362	0.569	-42.071	
0.800	0.240	-126.472	17.964	102.255	0.024	62.701	0.533	-44.121	
0.900	0.235	-134.500	16.345	97.645	0.027	61.910	0.504	-45.968	
1.000	0.232	-141.743	14.958	93.487	0.029	61.280	0.479	-47.614	
1.100	0.230	-148.265	13.770	89.661	0.031	60.570	0.457	-49.172	
1.200	0.230	-154.216	12.748	86.091	0.033	59.878	0.438	-50.696	
1.300	0.230	-159.761	11.850	82.773	0.036	59.238	0.421	-52.103	
1.400	0.231	-164.776	11.070	79.671	0.038	58.509	0.406	-53.483	
1.500	0.233	-169.782	10.383	76.687	0.040	57.719	0.392	-54.842	
1.600	0.234	-174.382	9.766	73.821	0.043	56.846	0.380	-56.285	
1.700	0.236	-178.496	9.213	71.086	0.045	56.001	0.369	-57.740	
1.800	0.238	177.334	8.725	68.404	0.047	54.999	0.358	-59.199	
1.900	0.241	173.487	8.277	65.836	0.050	53.983	0.348	-60.790	
2.000	0.244	169.856	7.874	63.295	0.052	52.923	0.338	-62.399	
2.200	0.251	162.836	7.172	58.413	0.057	50.729	0.319	-65.657	
2.400	0.259	156.208	6.578	53.682	0.062	48.414	0.301	-68.988	
2.600	0.268	150.081	6.068	49.042	0.067	45.958	0.283	-72.558	
2.800	0.277	144.221	5.628	44.575	0.072	43.380	0.266	-76.167	
3.000	0.288	138.650	5.244	40.174	0.077	40.713	0.248	-80.054	
3.500	0.319	125.843	4.470	29.452	0.090	33.634	0.204	-90.648	
4.000	0.352	113.999	3.873	18.944	0.102	26.177	0.158	-103.541	
4.500	0.389	103.406	3.406	8.713	0.113	18.415	0.113	-121.590	
5.000	0.431	92.903	3.011	-1.792	0.123	9.782	0.071	-156.899	
5.500	0.463	82.559	2.658	-11.364	0.131	2.534	0.054	148.652	
6.000	0.506	73.164	2.374	-21.684	0.138	-6.413	0.095	100.575	
6.500	0.516	66.705	2.179	-28.681	0.152	-10.089	0.112	92.309	
7.000	0.551	59.664	2.011	-37.894	0.164	-17.920	0.164	82.321	
7.500	0.610	50.773	1.808	-49.313	0.166	-29.630	0.246	65.957	
8.000	0.644	43.502	1.653	-58.585	0.172	-37.580	0.300	56.971	
8.500	0.683	35.816	1.496	-68.478	0.175	-46.984	0.361	47.167	
9.000	0.709	27.972	1.338	-77.310	0.173	-55.176	0.412	37.289	
9.500	0.736	20.858	1.212	-85.841	0.172	-63.448	0.449	29.117	

10.000	0.764	14.187	1.105	-95.600	0.173	-72.751	0.505	22.602
10.500	0.785	7.330	0.997	-104.961	0.171	-81.774	0.554	14.956
11.000	0.802	0.219	0.884	-113.744	0.164	-91.275	0.593	6.422
11.500	0.815	-6.751	0.791	-122.965	0.158	-100.952	0.631	-0.521
12.000	0.822	-13.843	0.690	-131.882	0.149	-111.108	0.667	-8.548

! DEEMBEDDED NOISE DATA

! FREQUENCY	FMIN	GAMMA	OPT	Rn
! (GHz)	(dB)	Mag	Ang	(NORMALIZED)

Using these parameter, we should compare on the sample display the modelised results and the measurements results, or directly show the error using equations. First we compare the results.

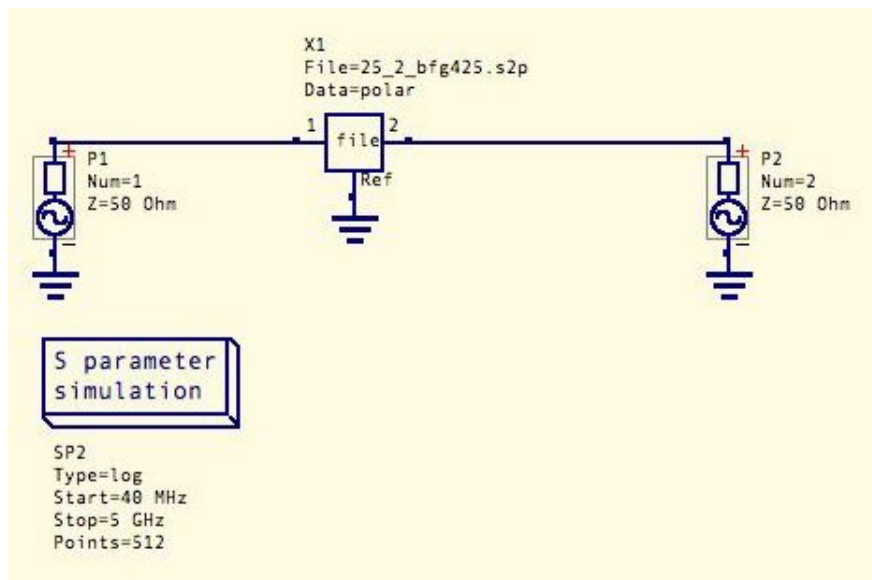

Figure 11: schematics used for S parameters from manufacturer

In the display that is used for the S parameters that we have simulated from our modelisation, you can add the results from the measurements files by adding a measurement of  $S_{i,j}$  using the right dataset with the combo box. You should obtain the difference between the two.

By doing this, you should obtain the results presented in the figure 12.

**IMPORTANT NOTE :** The differences, you should obtain are still on investigation for now.

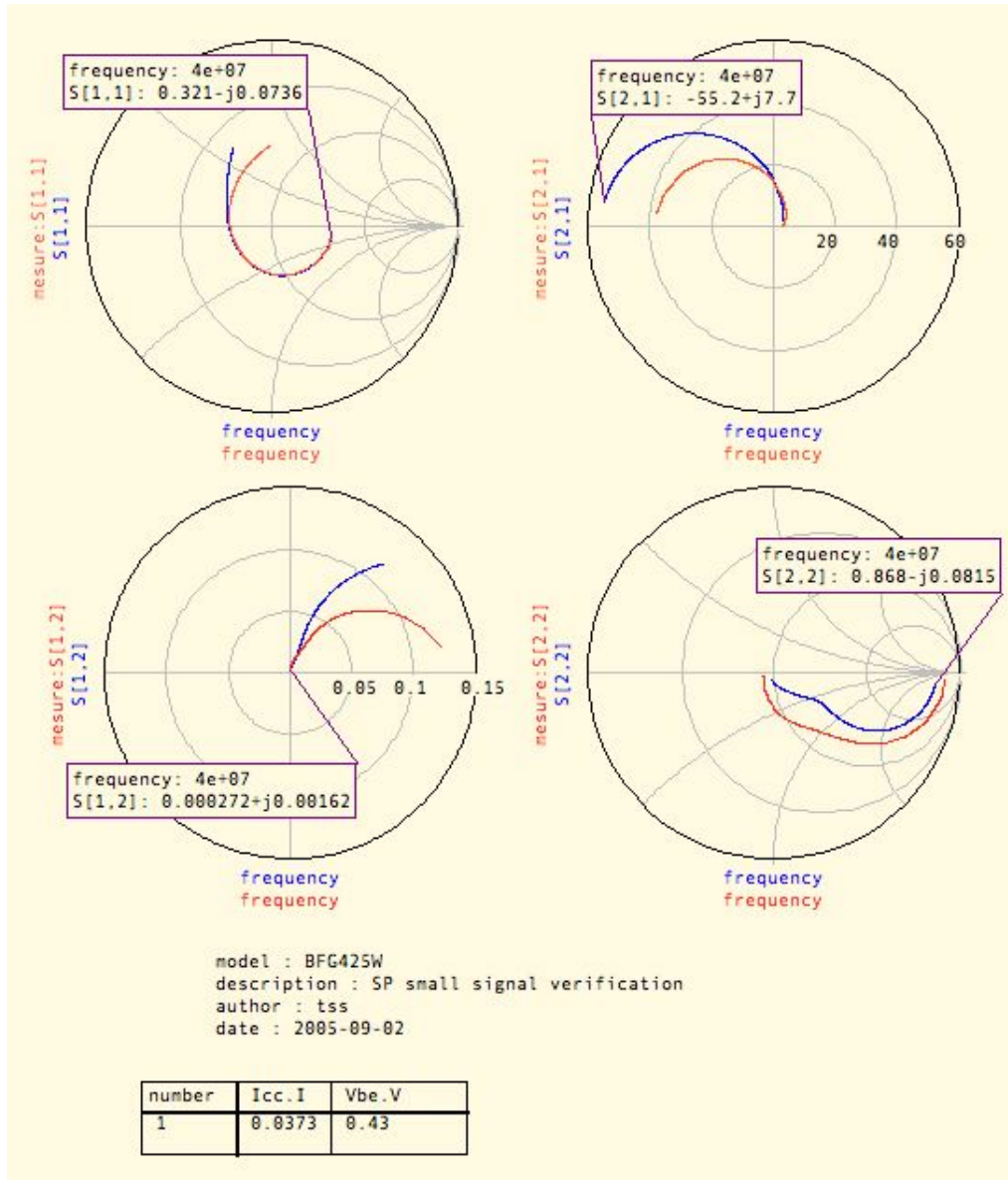

Figure 12: Results from model and from meares compared together