

# Qucs

---

## A Tutorial Transient Domain Flip-Flop Models for Mixed-Mode Simulation

Mike Brinson

---

Copyright © 2006 Mike Brinson <mbrin72043@yahoo.co.uk>

Permission is granted to copy, distribute and/or modify this document under the terms of the GNU Free Documentation License, Version 1.1 or any later version published by the Free Software Foundation. A copy of the license is included in the section entitled "GNU Free Documentation License".

## Introduction

One of the primary aims of the Qucs project is the development of a universal circuit simulator that allows circuit performance to be investigated from DC to microwave frequencies. Adding performance analysis in the digital domain makes Qucs a truly universal simulator. Qucs 0.0.8 was the first release to include digital simulation. Qucs digital simulation centres around VHDL using the FreeHDL VHDL compiler to generate a machine code simulation of a circuit under test. Release 0.0.8 includes built-in models for the basic digital gates and a number of the common sequential flip-flops. The Qucs gate models can be used in both digital and transient simulation. Unfortunately, the flip-flop models are only available in digital simulation. The current version of Qucs models flip-flops using VHDL and does not provide time domain models for transient simulation. This is an important omission which limits the Qucs simulator mixed-mode simulation capabilities. Mixed-mode simulation is a term commonly employed to describe the simulation of circuits that contain both analogue and digital components. In the real world circuits are, of course, not subdivided into neat boxes labelled analogue, S-parameter, digital or any other physical domain. So it is of some importance that Qucs device modelling be developed to allow circuits consisting of a range of different analogue and digital components, to be simulated at the same time. Normally such systems are simulated in the time domain using large signal transient simulation. Performance data being both analogue and digital expressed in tabular or graphical form. This tutorial note presents a number of transient simulation models for flip-flops based on structural digital circuits, describes their use, and outlines a number of example simulations derived from practical circuits.

## Latches and flip-flops

Sequential digital devices generically known as flip-flops (SR, D, JK and T types) are commonly classified into three major groups.

- Latches: basic or gated
- Pulse triggered flip-flops: master slave devices with or without data-lockout
- Edge-triggered flip-flops: leading or trailing edge triggered.

As the speed of electronic systems has increased so has the popularity of the single edge-triggered flip-flops over the slower master slave devices. Today most IC designs are based on D type edge-triggered devices rather than the earlier JK master slave devices. Our concern here is the development of a consistent set of models that allow the common flip-flops to be modelled accurately, and reliably,

in the transient time domain. In order to keep these models simple the D gated and edge-triggered devices have been chosen as the fundamental building blocks for the transient domain Qucs models. Using basic Boolean logic concepts it is straightforward to show that JK and T edge-triggered flip-flop models can be derived from the D flip-flop models.

## The gated D latch

The circuit diagram for a gated D latch constructed from two input nand gates is shown in Fig. 1<sup>1</sup>. Outputs Q and not Q (QB in Fig. 1) are derived from the two cross coupled nand gates connected as a basic SR nand latch. Fig. 2 shows the performance characteristics for this circuit. These were obtained using the simple test configuration shown in Fig. 3. Logic one digital signals are represented by 1V and logic 0 signals by 0V in the transient analysis domain. Propagation delays through the various circuit gates can be set by changing the delay time for each gate. Cross coupled gates are often a cause of simulation failure due to the fact that DC analysis fails to converge to a stable solution at the start of a transient simulation. One approach that helps to force a stable DC solution is to set Q and QB to known values, say logic 0 and logic 1, at the start of a simulation. In circuits like the basic gated D latch shown in Fig. 1, where asynchronous set and reset inputs are not included, this is not possible. However, flip-flops with asynchronous set and reset inputs do allow the state of a flip-flop to be determined at a given time in a simulation. In the examples that follow, whenever possible, the state of the latch or flip-flop devices is set at the start of a simulation. In the majority of the example circuits, device delays have also been set to zero. It therefore follows that most waveform plots show functional data rather than accurate timing characteristics. In many mixed-mode simulations the digital elements present in a design are often modelled as functional devices whose primary task is to generate the signals needed for the overall circuit to function. A more detailed discussion of the effects on transient simulation caused by including device timing delays is presented in a later section of these notes.

---

<sup>1</sup>Richard S. Sandige, Modern Digital Design, 1990, McGraw-Hill International Editions.

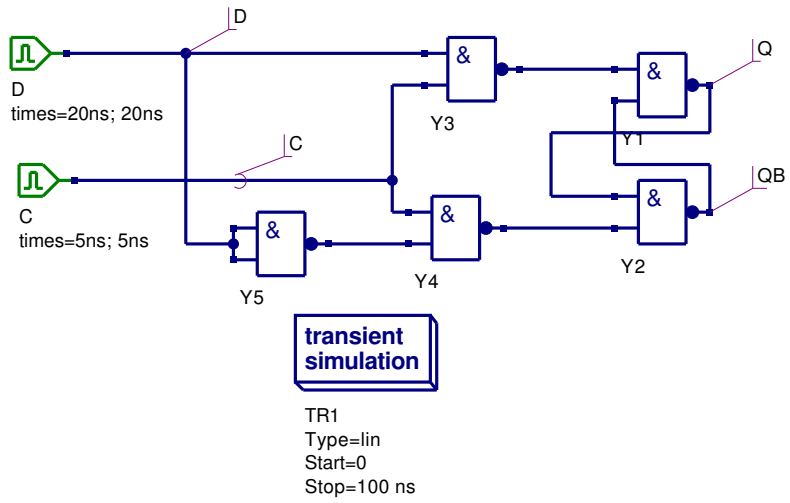

Figure 1: Gated D latch with digital signal generators D and C

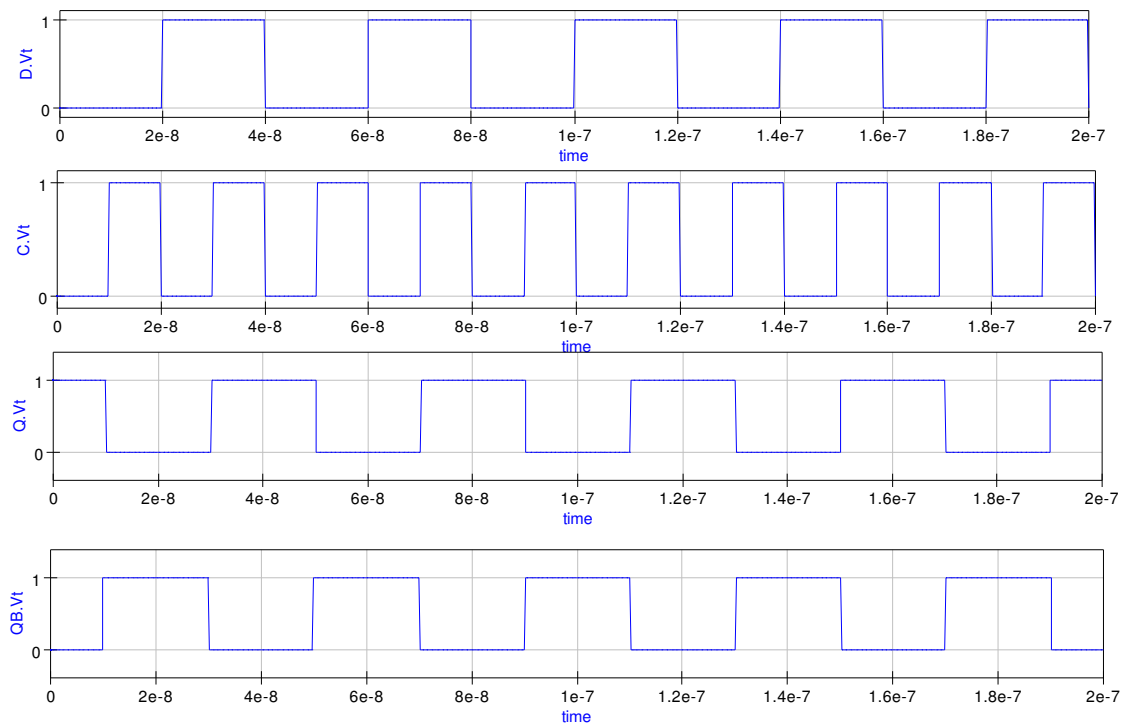

Figure 2: Gated D latch simulation waveforms

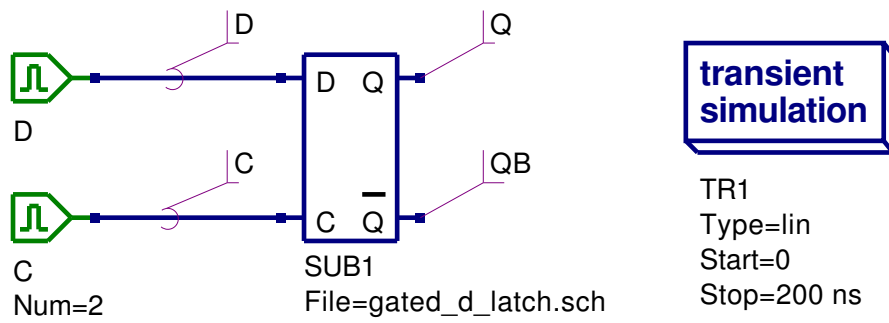

Figure 3: Gated D latch test circuit

## Edge-triggered D type flip-flop

The schematic for a positive edge-triggered D flip-flop is shown in Fig. 4<sup>2</sup>. Asynchronous set (SET) and reset (RESET) control inputs allow the flip-flop outputs Q and not Q (QB in Fig. 4) to be set to known values at the start of a simulation. The nand gates forming each of the cross coupled SR latches have their delay times set at 0 ns. The edge-triggered D device is a building block for both the JK and T types of flip-flop. A typical set of transient simulation test results for the D flip-flop model are illustrated in Fig. 5. These were obtained using the basic test configuration shown in Fig. 6.

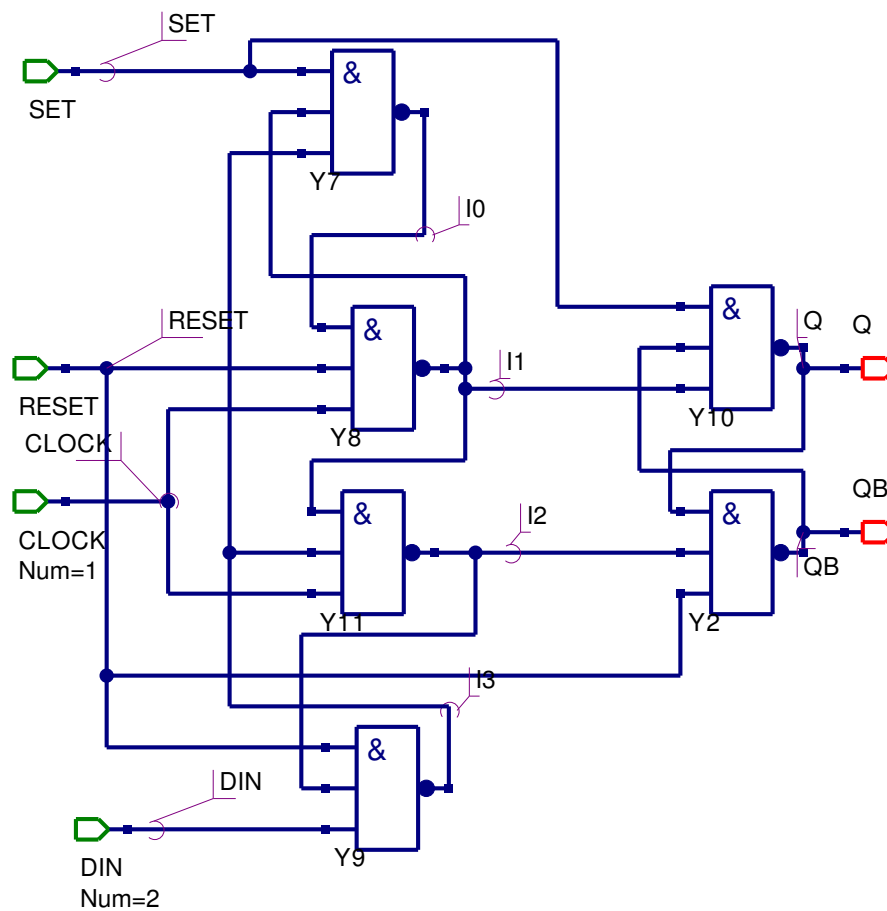

Figure 4: Positive edge-triggered D flip-flop circuit

<sup>2</sup>David A. Hodges and Horace G. Jackson, Analysis and Design of Digital Integrated Circuits, 1998, Second edition, McGraw-Hill Book Company.

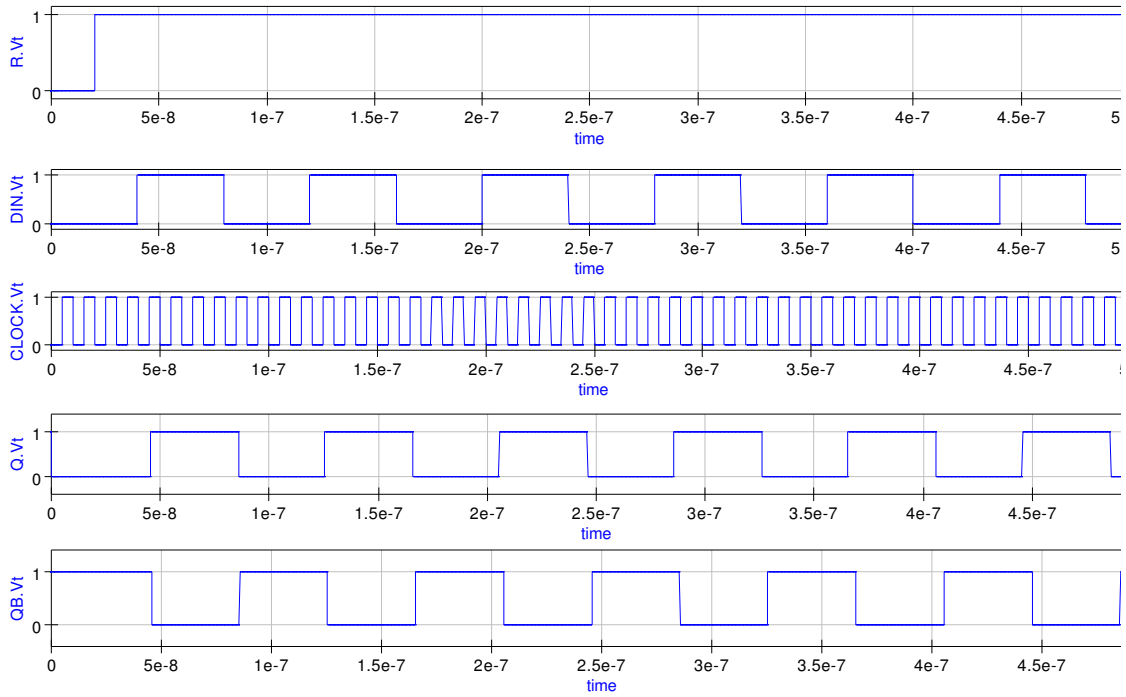

Figure 5: Transient waveforms for the circuit shown in Fig. 6

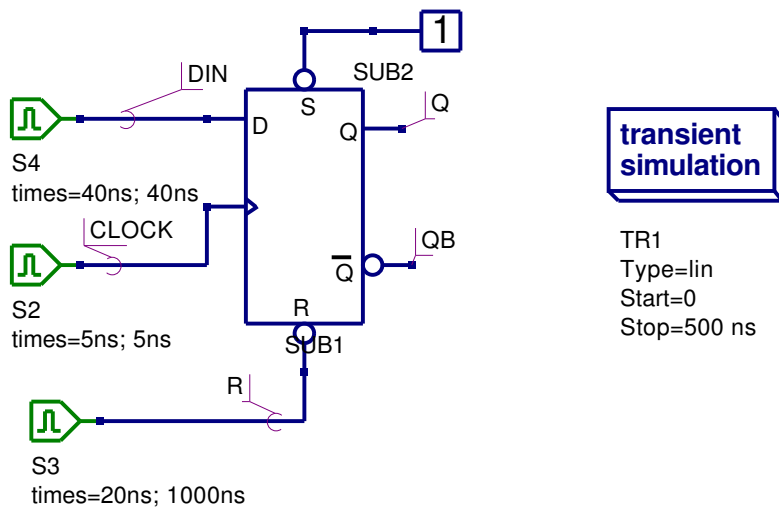

Figure 6: D flip-flop test circuit

## The edge-triggered JK flip-flop

A leading edge-triggered JK flip-flop can be constructed using a positive edge-triggered D flip-flop and external logic<sup>3</sup>. The external logic generates the required JK flip-flop characteristic equation given by

$$Q^+ = J.\bar{Q} + \bar{K}.Q$$

Where  $Q$ ,  $\bar{Q}$ ,  $J$  and  $\bar{K}$  are the current state values of the device signals and  $Q^+$  is the next state value of  $Q$  following the rising edge of the device clock pulse. The schematic diagram for the edge triggered flip flop is shown in Fig. 7 and a typical set of test waveforms in Fig. 8. These were obtained using the test circuit shown in Fig. 9.

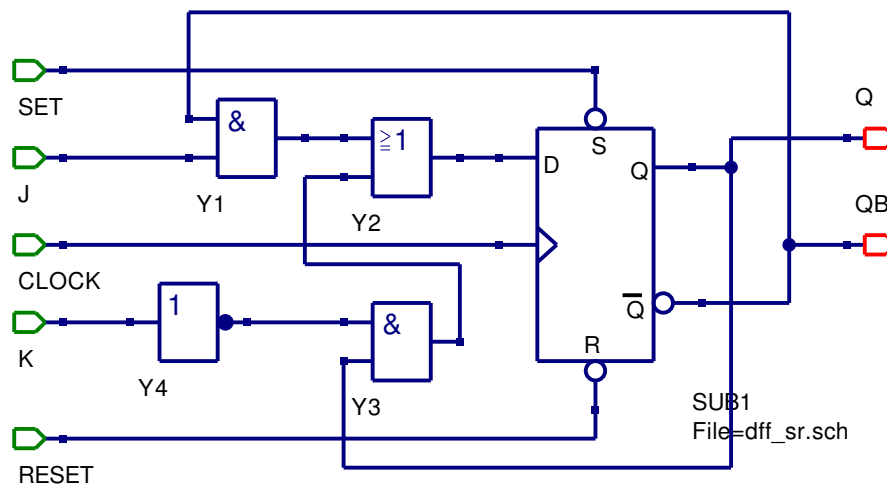

Figure 7: Positive edge-triggered JK flip-flop circuit

<sup>3</sup>M. Morris Mano and Charles R Kime, Logic and Computer Design Fundamentals, 2004, Third edition, Pearson Education International, Prentice Hall



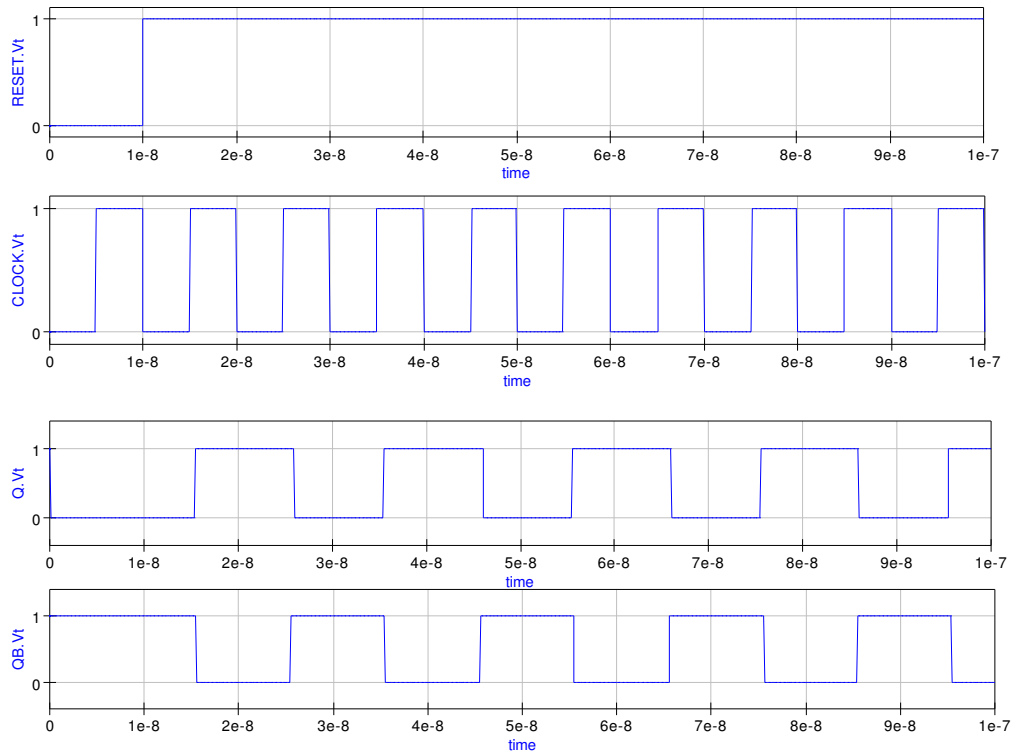

Figure 8: Transient waveforms for the circuit shown in Fig. 9

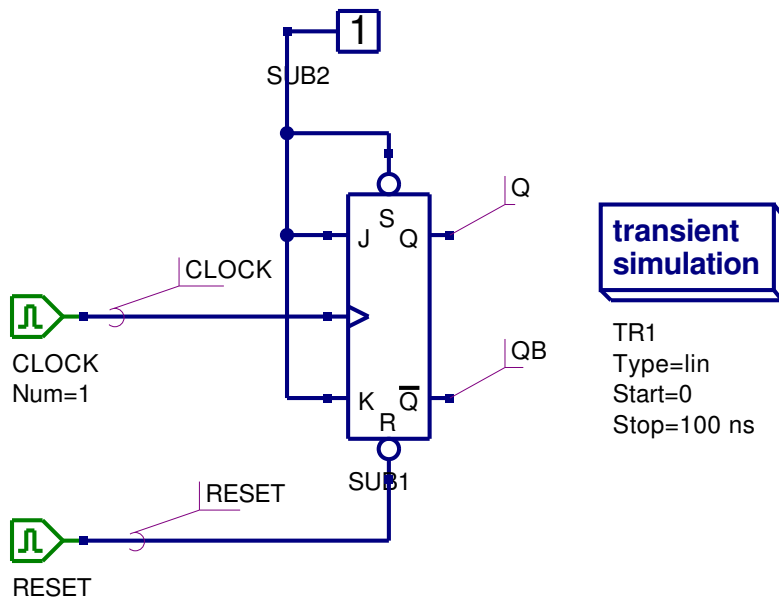

Figure 9: JK flip-flop test circuit showing JK operating in toggle mode

## The edge-triggered T flip-flop

The characteristic equation for a leading edge-triggered flip-flop is<sup>4</sup>

$$Q^+ = T \oplus Q$$

where the symbols have the same meaning as the JK flip-flop. The circuit diagram, test waveforms and test circuit for the edge-triggered flip-flop are given in Figures 10 to 12.

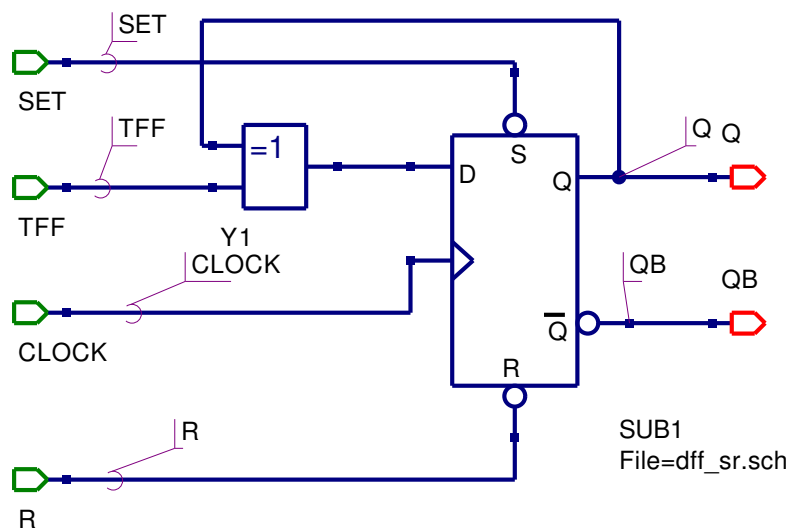

Figure 10: Positive edge-triggered T flip-flop circuit

---

<sup>4</sup>See footnote 2.

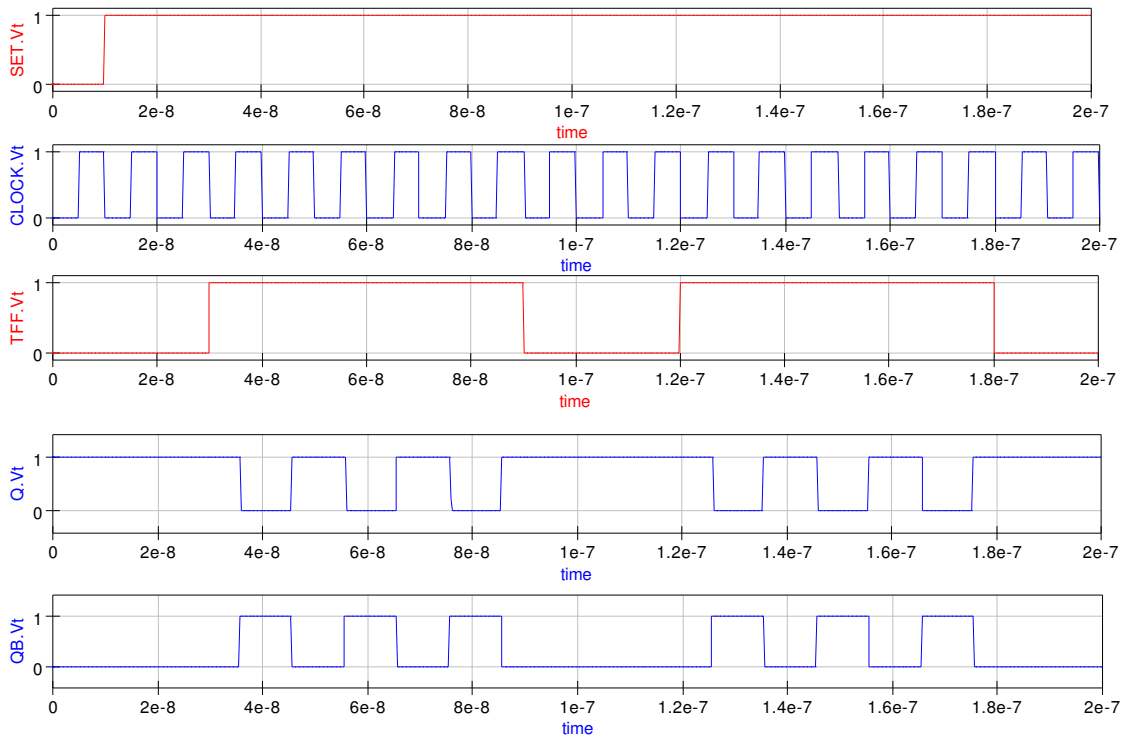

Figure 11: Transient waveforms for the circuit shown in Fig. 12

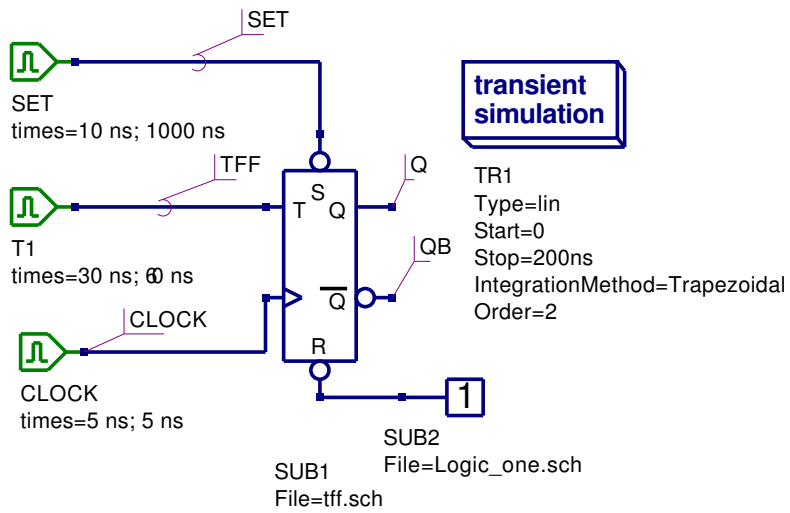

Figure 12: T flip-flop test circuit

## Two example digital circuits

- **A synchronous BCD up-counter:** Figure 13 shows a synchronous BCD up-counter constructed from four edge-triggered JK flip flops connected as toggle flip-flops. The input signal waveforms and the corresponding counter outputs Q0, Q1, Q2 and Q3 are illustrated in Fig. 14. These simulation results were obtained using the default trapezoidal integration method with order 2.

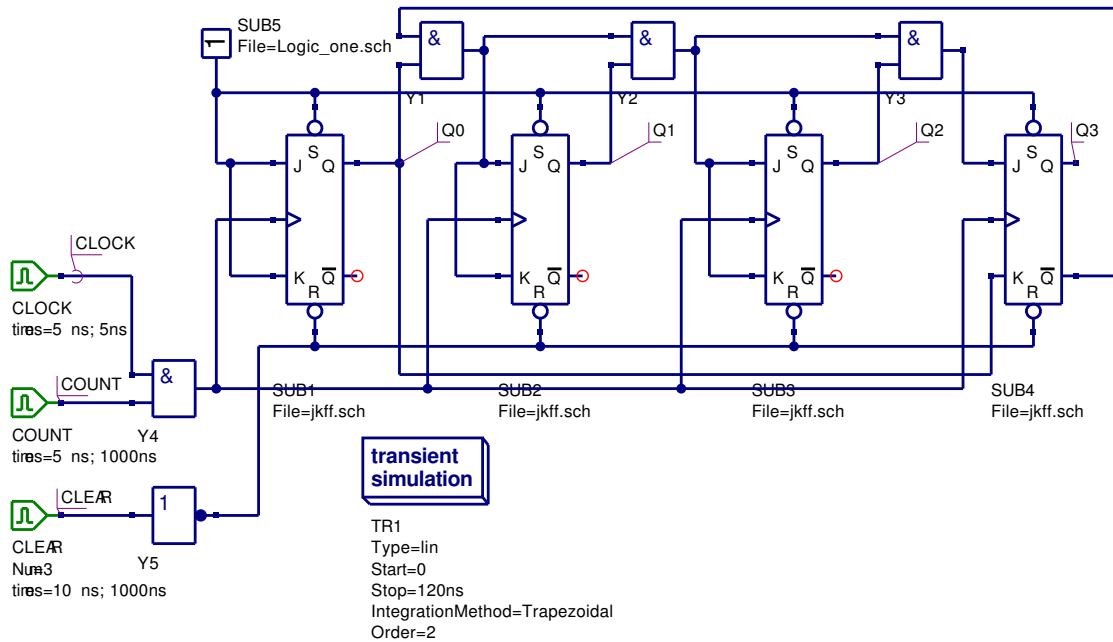

Figure 13: Synchronous BCD up-counter circuit

At the start of simulation signal CLEAR is set to logic 1 which in turn causes the counter to be reset to 0000. Similarly signal COUNT has to be set to 1 for counting to take place. Notice that the counter counts from 0 to 9 and then resets to 0.

- **A simple state machine:** Figure 15 shows a simple sequential state machine with input X and outputs Y1 and Y2. The outputs are synchronised to the input clock. The state equations for this example are

$$J = \overline{X}, K = 1, Y1 = \overline{Q0}.\overline{X}, Y2 = Q0$$

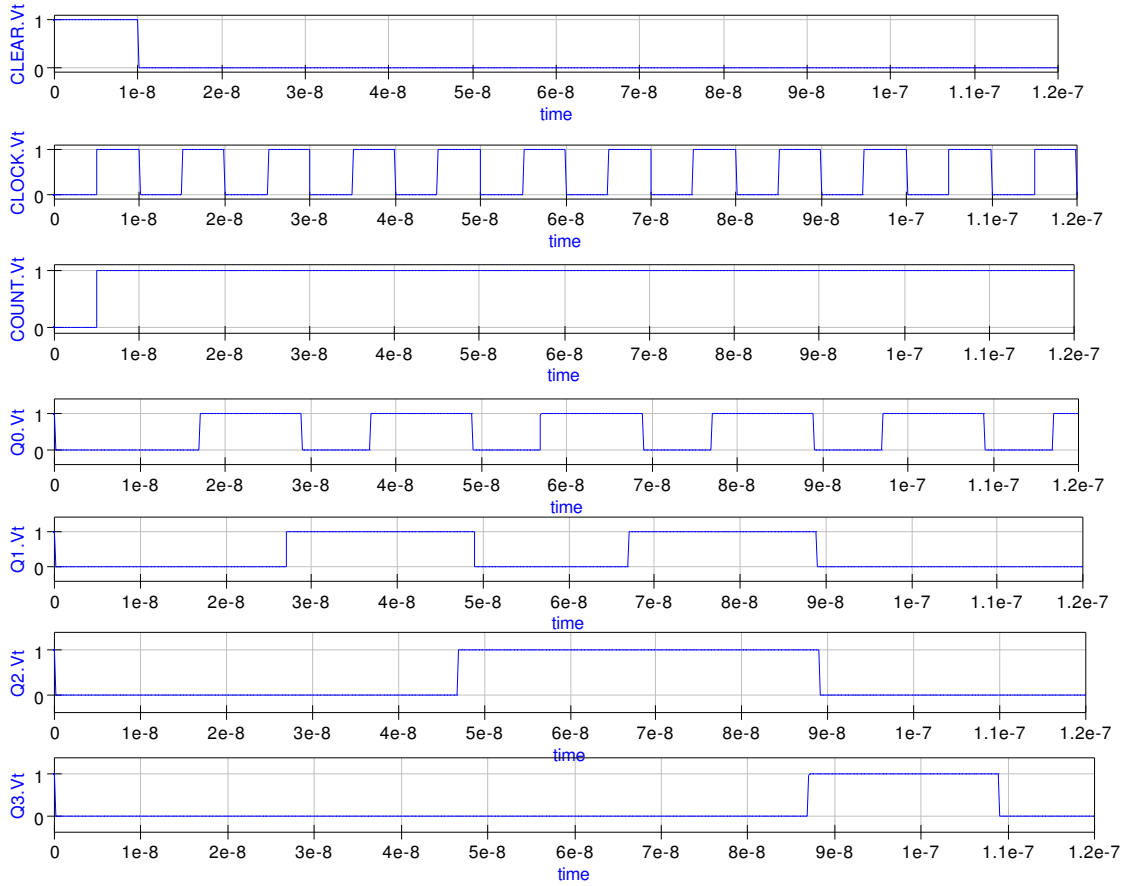

Figure 14: Transient waveforms for the circuit shown in Fig. 13

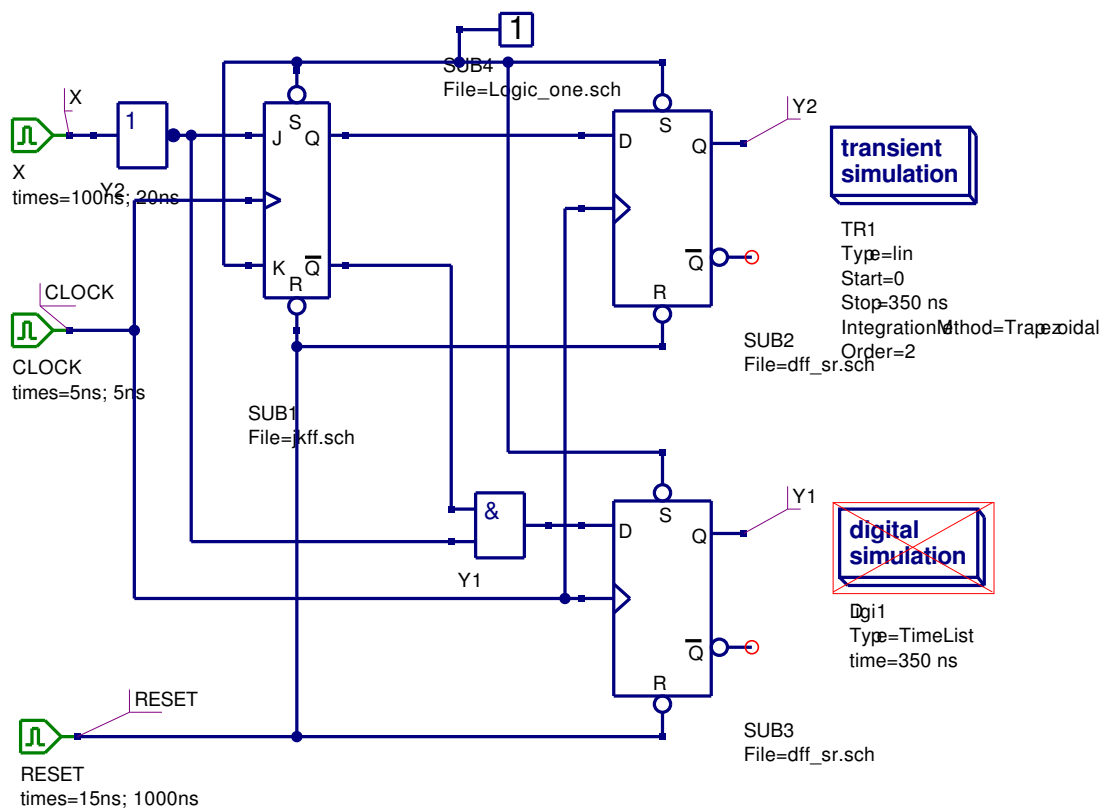

Figure 15: A simple state machine

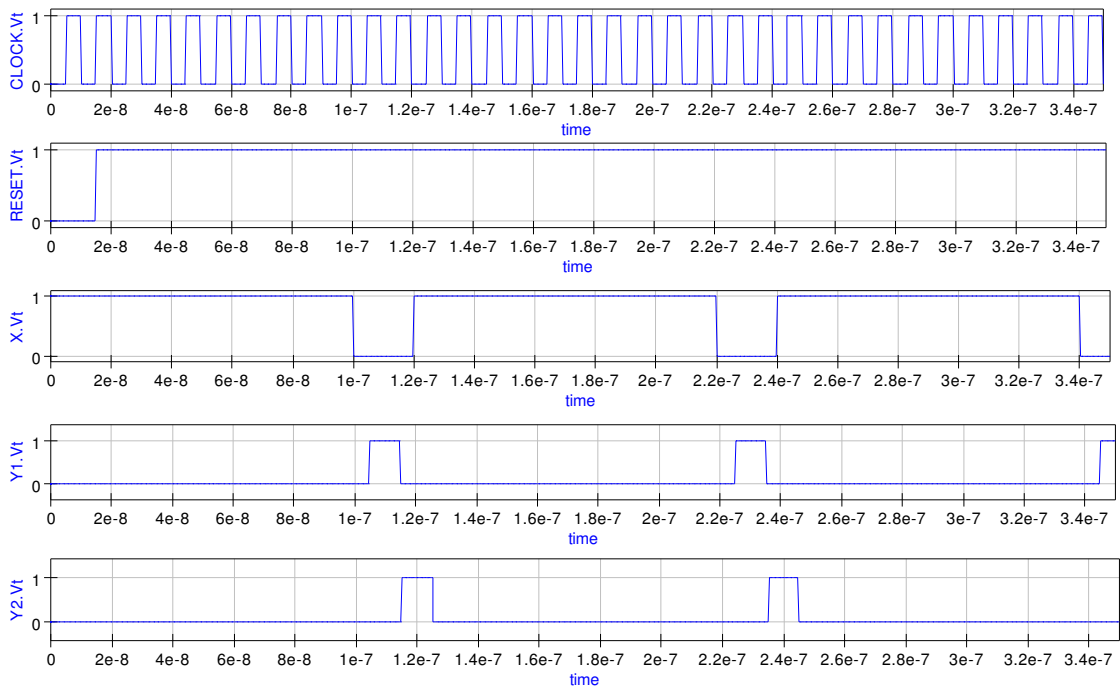

Figure 16: Transient waveforms for the circuit shown in Fig. 15

## VHDL code for the transient domain flip-flop models

Although the primary purpose for developing the transient domain flip-flop models is the simulation of mixed-mode circuits, it is worth noting that because the models have been constructed from Qucs gate primitives using a bottom-up design approach, Qucs can also use the models for digital simulation. Moreover, provided the circuit being simulated does not contain any purely analogue components Qucs will generate a VHDL model testbench that describes the function and test sequence for the circuit being simulated. Shown in Fig. 17 is a digital timelist waveform plot for the synchronous BCD up-counter introduced in the previous section of these notes. Listing 1 lists the VHDL code generated by Qucs for the synchronous BCD up-counter example.

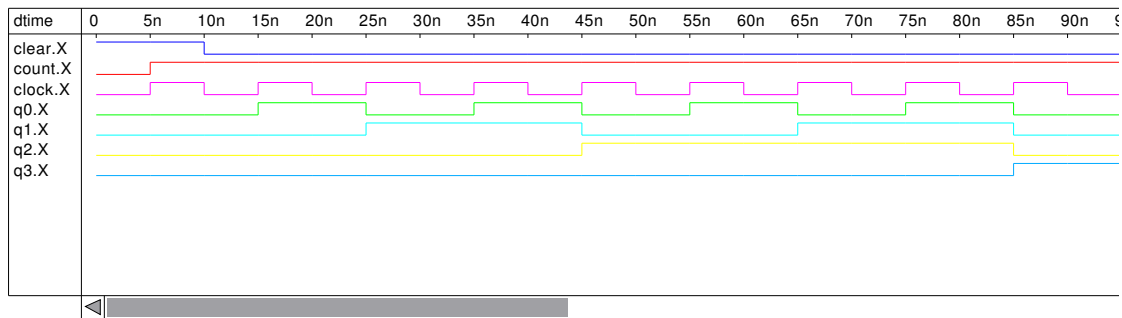

Figure 17: Digital TimeList waveforms for the circuit shown in Fig. 13

Listing 1: VHDL testbench code for the circuit shown in Fig. 13

— Qucs 0.0.9  
— /mnt/hda2/Digital\_Subcircuits\_prj/Sync\_BCD\_counter.sch

```
entity Sub_Logic_one is
  port (nnout_L1: out bit);
end entity;
use work.all;
architecture Arch_Sub_Logic_one of Sub_Logic_one is
  signal gnd,
         L1 : bit;
begin
  gnd <= '0';
  L1 <= not gnd;
  nnout_L1 <= L1 or '0';
```



```
end architecture;
```

```
entity Sub_dff_sr is
  port (CLOCK: in bit;
        DIN: in bit;
        nnout_Q: out bit;
        nnout_QB: out bit;
        RESET: in bit;
        SET: in bit);
end entity;
use work.all;
architecture Arch_Sub_dff_sr of Sub_dff_sr is
  signal I0,
         I2,
         I1,
         I3,
         QB,
         Q : bit;
begin
  nnout_QB <= QB or '0';
  nnout_Q <= Q or '0';
  I1 <= not (CLOCK and RESET and I0);
  I3 <= not (DIN and I2 and RESET);
  QB <= not (RESET and I2 and Q);
  Q <= not (I1 and QB and SET);
  I0 <= not (I3 and I1 and SET);
  I2 <= not (CLOCK and I3 and I1);
end architecture;
```

```
entity Sub_jkff is
  port (nnnet6: in bit;
        nnet1: in bit;
        nnet8: in bit;
        nnout_nnet3: out bit;
        nnout_nnet7: out bit;
        nnet9: in bit;
        nnet10: in bit);
end entity;
```

```

use work.all;
architecture Arch_Sub_jkff of Sub_jkff is
    signal nnnet0 ,
            nnnet2 ,
            nnnet4 ,
            nnnet5 ,
            nnnet7 ,
            nnnet3 : bit;
begin
    nnnet0 <= not nnnet1;
    nnnet2 <= nnnet3 and nnnet0;
    nnnet4 <= nnnet2 or nnnet5;
    nnnet5 <= nnnet6 and nnnet7;
    nnout_nnnet7 <= nnnet7 or '0';
    nnout_nnnet3 <= nnnet3 or '0';
    SUB1: entity Sub_dff_sr port map (nnnet8 , nnnet4 , nnnet3 ,
                                       nnnet7 , nnnet10 , nnnet9);
end architecture;

entity TestBench is
end entity;
use work.all;

architecture Arch_TestBench of TestBench is
    signal CLEAR,
            COUNT,
            CLOCK,
            Q3,
            Q0,
            Q1,
            Q2,
            nnnet0 ,
            nnnet1 ,
            nnnet2 ,
            nnnet3 ,
            nnnet4 ,
            nnnet5 ,
            nnnet6 ,
            nnnet7 ,
            nnnet8 ,

```

```

        nnnet9 : bit;
begin
SUB5: entity Sub_Logic_one port map (nnnet0);
nnnet1 <= Q0 and nnnet2;
nnnet3 <= Q1 and nnnet1;
nnnet4 <= Q2 and nnnet3;
SUB2: entity Sub_jkff port map (nnnet1, nnnet1, nnnet5,
                                Q1, nnnet6, nnnet0, nnnet7);

SUB3: entity Sub_jkff port map (nnnet3, nnnet3, nnnet5,
                                Q2, nnnet8, nnnet0, nnnet7);
SUB1: entity Sub_jkff port map (nnnet0, nnnet0, nnnet5,
                                Q0, nnnet9, nnnet0, nnnet7);

nnnet5 <= COUNT and CLOCK;
nnnet7 <= not CLEAR;

CLEAR: process
begin
    CLEAR <= '1'; wait for 10 ns;
    CLEAR <= '0'; wait for 1000 ns;
end process;

COUNT: process
begin
    COUNT <= '0'; wait for 5 ns;
    COUNT <= '1'; wait for 1000 ns;
end process;

CLOCK: process
begin
    CLOCK <= '0'; wait for 5 ns;
    CLOCK <= '1'; wait for 5 ns;
end process;

SUB4: entity Sub_jkff port map (nnnet4, Q0, nnnet5,
                                Q3, nnnet2, nnnet0, nnnet7);
end architecture;

```

## Generating a library of mixed-mode digital components

The Qucs project facilities offer users a simple and convenient approach to developing libraries of components that are linked by a common theme; in these notes this is digital component models for transient simulation. To form a library create a new folder, at a point on a disk file system that users have read/write access, giving it a suitable name, for example

```
flip_flop_models_tran_sim_prj.
```

Next move into the new library folder a copy of each of the schematic capture files for the flip-flop models introduced in these notes. These are:

```
dff_sr.sch , jkff.sch , tff.sch , and gated_d_latch.sch .
```

A copy of the schematic for setting nodes to logic one is also required

```
( logic_one.sch ) .
```

These models are then freely available for use in any projects which users are working on. They can be copied into such projects using the "Add files to Project..." menu button found under the Qucs Project drop-down menu. Similarly any new models developed as part of a project can be added to the library and used again in the future.

## Digital component propagation time delays and transient simulation numerical stability

Transient simulation is in general much slower than digital simulation using VHDL generated machine code. The large signal transient simulation models of flip-flops and other sequential digital devices are intended for use in mixed-mode circuit simulation rather than being used for pure digital circuit simulation. An interesting, and indeed very important question, relates to the efficiency, and accuracy, of the numerical analysis algorithms employed in the integration routines that are central to transient circuit simulation. Qucs allows users to select the algorithm they wish to employ for transient simulation. The available algorithms are Trapezoidal, Euler, Gear and Adams Moulton; in each case the algorithm order can be set from 1 to 6. The second order Trapezoidal integration algorithm is used by Qucs as the default for transient simulation. To test which of these algorithms offers the most time efficient solution to the transient simulation of digital circuits, that include flip-flops, the BCD counter shown in Fig. 13 was used as a test case and repeatedly simulated using different integration routines and algorithm orders.

Order	Trapezoidal	Euler	Gear	Adams Moulton
1	1	1.62	1.65	1.62
2	1	1.62	0.44	1
4	1	1.62	1.28	0.39
6	1	1.62	0.28	0.18

Table 1: Relative simulation times for the circuit shown in Fig. 13

Order	Number of rejections	Average time step
1	1470	5.17737e-12
2	1750	9.4585e-12
4	1454	2.866e-11
6	61	5.76646e-11

Table 2: Number of rejections and average time step data for the Adams Moulton algorithm

The test results are shown in Table 1. Very little difference was found between circuits where the cross coupled gates both had zero propagation delays and the case where one gate had 0.5ns delay and the other zero delay.

One obvious fact emerges from the data given in Table 1; namely that the Adams Moulton higher order integration routines appear to be faster than the default trapezoidal algorithm. This is corroborated by the average time step and number of rejection data points output by Qucs at the end of a simulation. Table 2 lists this data for the Adams Moulton algorithm tabulated in Table 1.

Table 2 points to the increase in average time step and the dramatic reduction in the number of simulation solution rejections as the probable reason for the reduction in transient simulation time when using the higher order Adams Moulton integration routines. However, other factors may influence the choice of integration routine. Often speed is not the only criteria that is of importance when simulating large complex circuits. Consider the following case (the circuit shown in Fig. 13 with order 6 Adams Moulton transient analysis integration); setting one of the gate delays to 1ns, and the other to 0ns, in each of the RS latches in the edge-triggered D flip-flop yields the signal waveforms illustrated in Fig. 18. Clearly here the solution is incorrect pointing to probable numerical instability caused by the choice of integration routine.

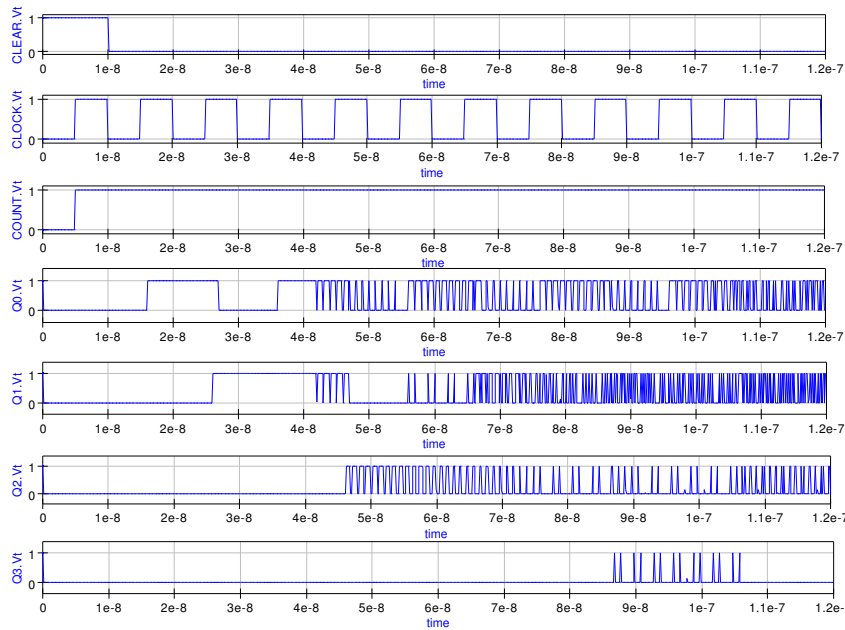

Figure 18: Digital TimeList waveforms for the circuit shown in Fig. 13

## Mixed-mode example simulations

Mixed-mode simulation involves the simulation of circuits that contain electronic devices and circuits from different physical domains; the most obvious being circuits with a mixture of analogue and digital components. Qucs has developed to a point where it can handle this type of circuit given device models that can span across the different physical domains. In the future such circuits are likely to incorporate components from other domains, including for example, digital signal processing components (DSP) and possibly nano mechanical devices. Multi-domain simulation adds additional complexity to the simulation process not normally found in single domain simulation. Each domain usually represents signal data in a specific way attributed to a given domain; voltage and current for analogue quantities, boolean '1' and '0' for digital signals and floating point numbers for DSP. Hence, signals passing from one domain to another have to be converted from one format to another. These conversion elements are often called node-bridges and form an essential part of the mixed-mode simulation process. The three examples that are introduced in this section of these notes have been chosen to illustrate a number of the basic ideas concerned with mixed-mode simulation of circuits containing analogue and digital components, and to show how Qucs deals with this type of simulation. In the last section the importance of correct selection of integration routine when simulating circuits in the time domain was stressed. Mixed-mode

circuits often include a wide diversity of components that exhibit widely differing time constants. This makes the problem of numerical stability versus simulation run time even more critical. With the explicit numerical integration routines, like the trapezoidal routine, numerical instability results if the simulation time step becomes much larger than the smallest time constant in a circuit. Hence, to achieve successful completion of a simulation the integration time step must be reduced which in turn makes the overall simulation time increase significantly. The implicit Gear algorithm<sup>5</sup> does not suffer from this problem and is the natural choice for circuits with components that have widely differing time constants.

- Example 1: Analogue waveform driven digital devices with output node-bridge.

The circuit in Fig. 19 shows an analogue voltage source driving a digital inverter with a node-bridge element processing the inverter output signal. The input signal is a sinusoidal voltage of amplitude 1V peak. The inverter output signal, V1 in Fig. 19, has a nonsymmetrical mark to space ratio because the threshold point for the inverter is set at 0.5V; the halfway point for the two logic levels. The node-bridge element is basically a voltage controlled voltage source where the device gain and time delay can be programmed. In this first example the gain has been set to 5 and the time delay to 0.5ns. Figure 20 illustrates the simulation TimeList waveforms for this example mixed-mode circuit. The node-bridge shown in Fig. 19 is a very basic device. Moreover, by adding additional features, parameters like fall and rise time can be set to specific values. The next example demonstrates the use of an active node-bridge.

---

<sup>5</sup>The Gear integration algorithm is a powerful method for solving stiff systems of differential equations, see Donald A. Calahan, *Computer Aided Network Design*, Revised edition, 1972, McGraw-Hill.

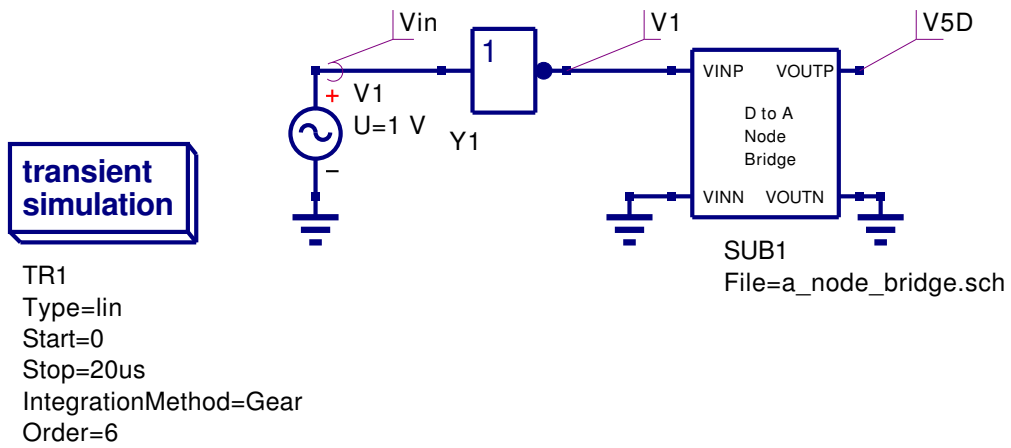

Figure 19: Analogue waveform driven digital device with output node-bridge

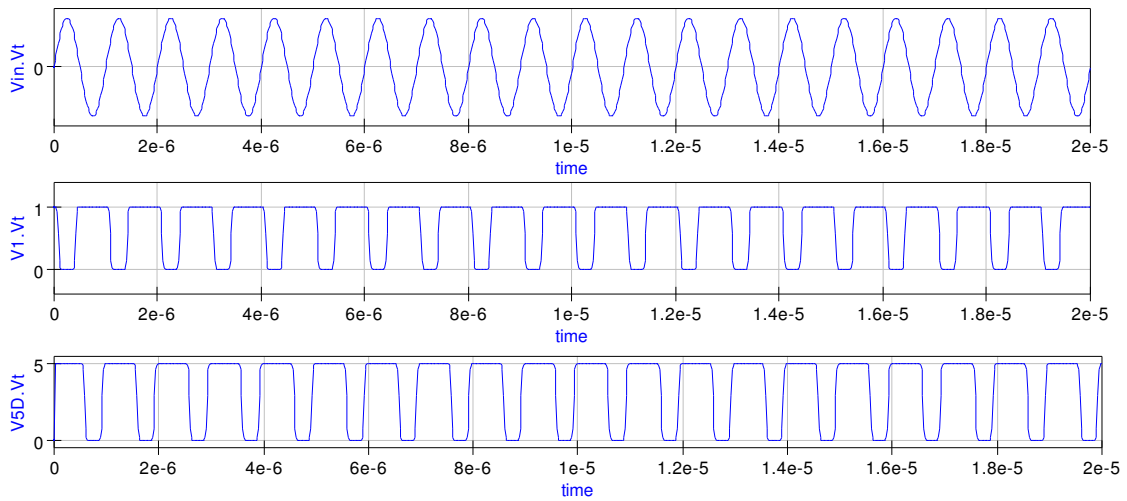

Figure 20: Digital TimeList waveforms for the circuit shown in Fig. 19



- Example 2: Pulse driven digital inverter with an active node bridge.

Illustrated in Fig. 21 is a similar circuit to the previous example. In Fig. 21 a pulse generator drives a digital inverter. The inverter output signal is processed by an active node-bridge derived from a basic BJT switching amplifier. The output waveforms for this circuit are shown in Fig. 22. Notice that the pulse rise and fall times are determined by the node-bridge amplifier and that the resulting analogue signal amplitude is set to 5V.

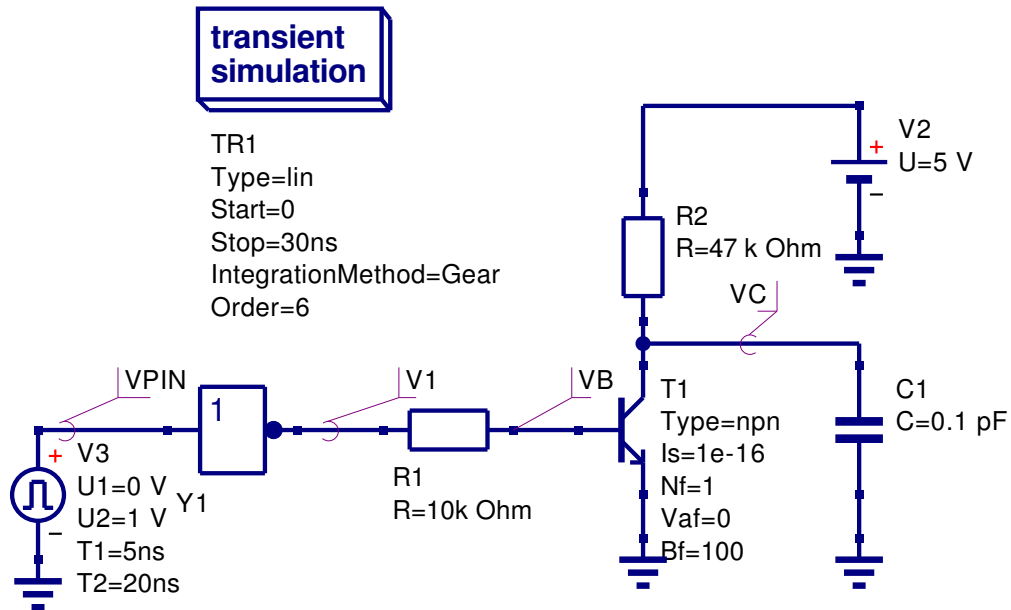

Figure 21: Pulse driven digital inverter with active node-bridge

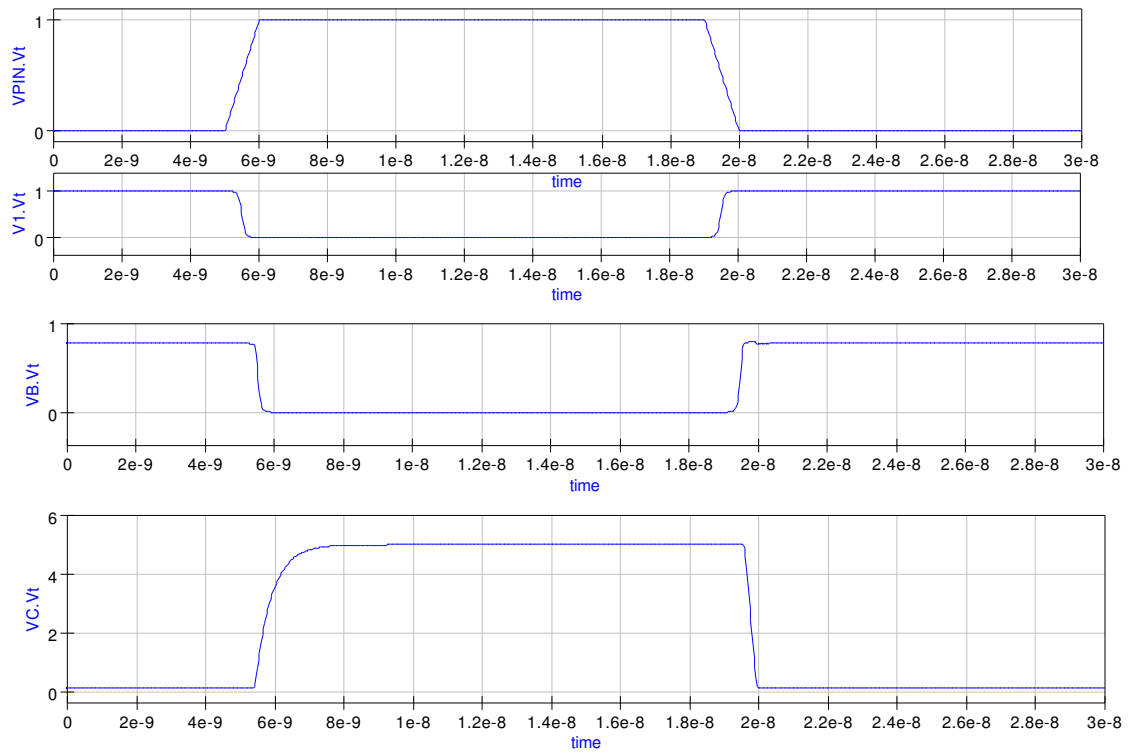

Figure 22: Digital TimeList waveforms for the circuit shown in Fig. 21

- Example 3: A more complex mixed-mode simulation example.

The circuit shown in Fig. 23 brings together a number of the ideas outlined in these tutorial notes. A 4-bit digital signal is generated from a simple asynchronous binary counter operated from a digital clock signal. The counter output is transformed to the analogue domain using a simple node-bridge, of the type introduced in mixed-mode example 1. A 4-bit binary weighted DAC converts the transformed node-bridge signals into the final analogue output signal. The DAC operational amplifier is modelled as a gain block with a single pole frequency response and DC voltage output limiting. The output waveforms for this example are shown in Fig. 24 and the details of the operational amplifier model in Fig. 25.

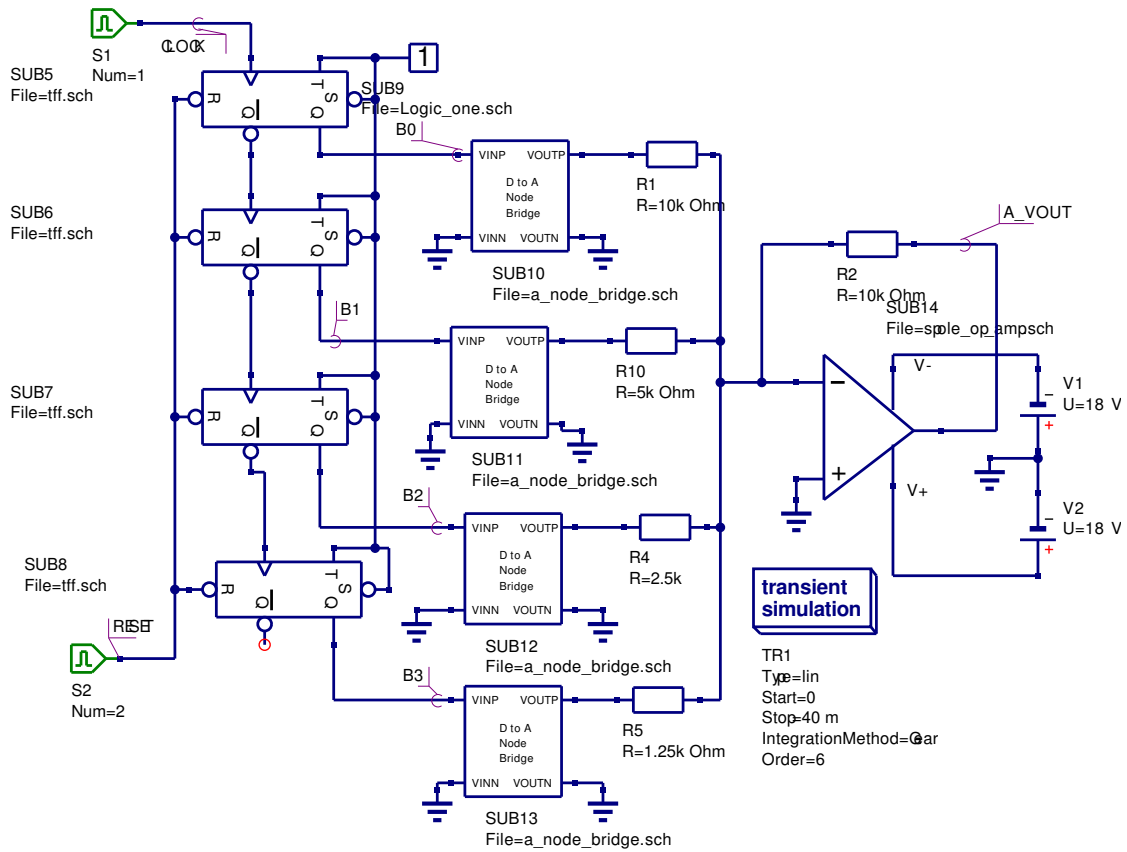

Figure 23: A more complex analogue-digital mixed-mode simulation example

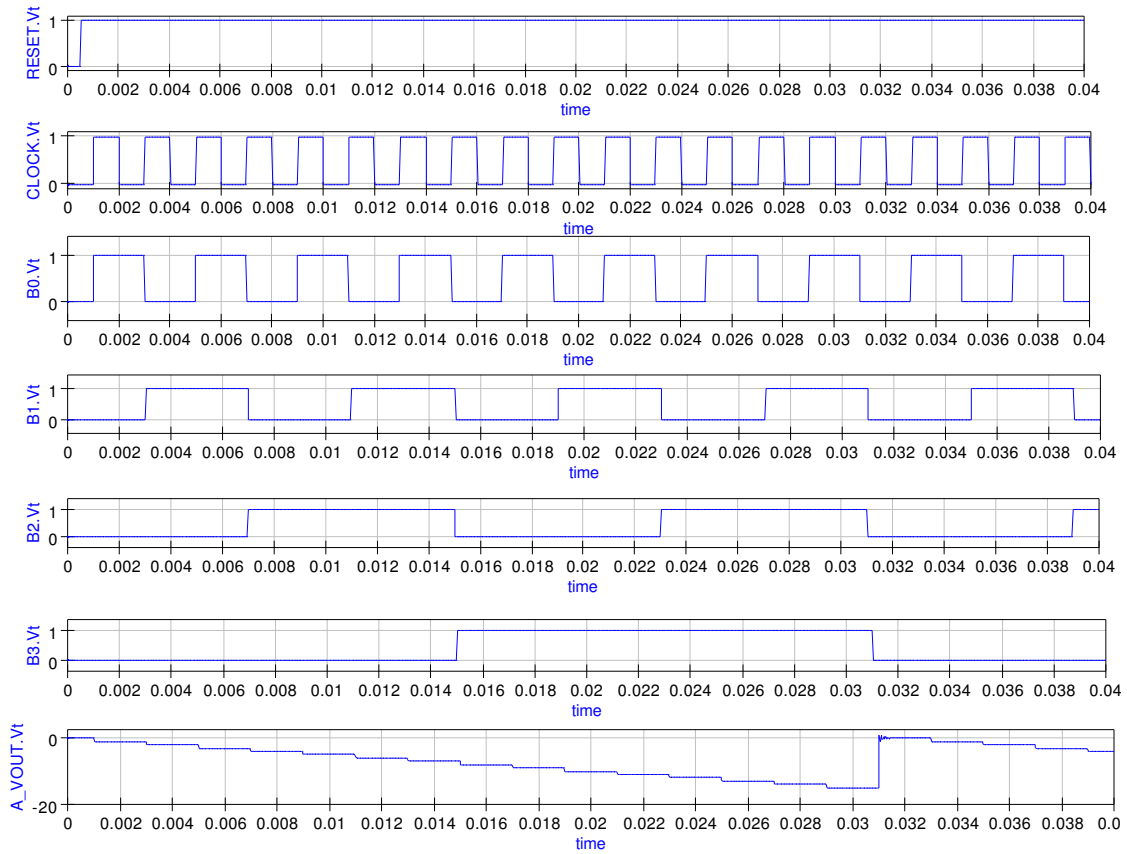

Figure 24: Digital TimeList waveforms for the circuit shown in Fig. 23

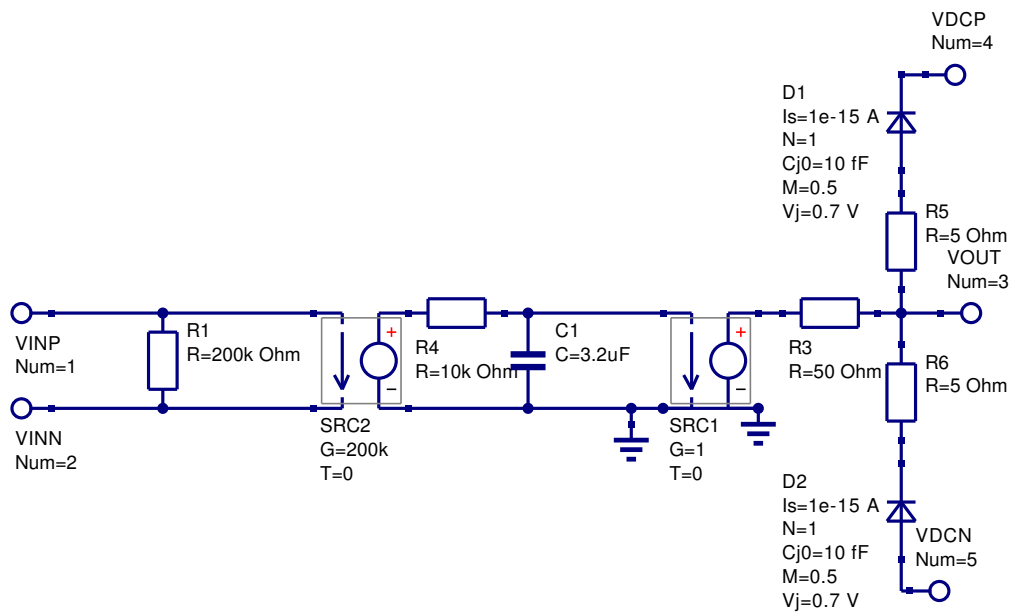

Figure 25: Operational amplifier model with  $R_{in} = 200k \Omega$ , pole frequency = 5Hz, DC differential gain = 200k and  $R_{out} = 50 \Omega$

## End Note

The examples described in these notes were all simulated using the latest CVS code version of Qucs. Since release of version 0.0.8, Qucs has matured enough to allow it to be used for mixed-mode simulation and many of the known bugs in Qucs 0.0.8 will be corrected with the release of Qucs 0.0.9 some time in the future. Release 0.0.9 will represent another important step in the development of a truly universal simulator. However, much more work needs to be done on the development of models for use across the different physical domains. My thanks to Michael Margraf and Stefan Jahn for all their hard work in correcting the bugs which surfaced while the examples presented in this tutorial note were being tested.