

Qucs

Report

Verilog-A Logarithmic Amplifier Macromodel

Mike Brinson

Copyright © 2008 Mike Brinson <mbrin72043@yahoo.co.uk>

Permission is granted to copy, distribute and/or modify this document under the terms of the GNU Free Documentation License, Version 1.1 or any later version published by the Free Software Foundation. A copy of the license is included in the section entitled "GNU Free Documentation License".

Introduction

The development of simulation component and device models in many ways reflects how circuit simulator functionality has improved with increasing personal computer computational power. Early circuit simulators were often restricted to the DC, AC and transient analysis domains. Similarly, in the early days of circuit simulation, the available types of component and device models were extremely limited, often being confined to the fundamental passive components, simple voltage and current sources and the basic semiconductor devices. Adding new models to a circuit simulator was, in most instances, a complex task. Today this picture is changing. Modern circuit simulators, like Qucs, are equipped with an ever widening selection of simulation tools plus increasingly sophisticated modelling tools. The later allows easy construction of subcircuit models, linear and non-linear macromodels, equation defined device models, and Verilog-A compact device models. This report describes how a compact macromodel of a logarithmic amplifier can be constructed from a model description written in the Verilog-A hardware description language, compiled to C++ code using the ADMS compiler plus Qucs XML interface, and linked to the main body of Qucs C++ code¹. The logarithmic amplifier model demonstrates an approach to Qucs modelling which allows high-level functional models of integrated circuits to be added to the existing range of Qucs component and device models.

The ideal logarithmic amplifier

The operation of an ideal logarithmic amplifier² is defined by the function given in equation (1).

$$V_{out}(ideal) = K_v \cdot \log \left(\frac{I_i}{I_r} \right) \quad (1)$$

The device accepts two input currents (I_i and I_r) and outputs voltage $V_{out}(ideal)$ which is proportional to the base ten logarithm of the current ratio I_i/I_r , where the constant of proportionality is K_v volts per decade. In equation (1) current I_r is called the reference current and current I_i represents the amplifier input signal. The primary purpose of a logarithmic amplifier is not to amplify input signals but

¹A detailed description of the procedure for the compilation of Verilog-A models with ADMS and linking of the resulting C++ code to Qucs can be found in the Qucs publication : “Qucs Description: Verilog-AMS interface”, by Stefan Jahn, Hélène Parrutte, located at <http://qucs.sourceforge.net/docs.html>.

²A very good introduction to the theory of logarithmic amplifiers is given in Sergio Franco, Design with Operational amplifiers and Analog Integrated Circuits, McGraw-Hill Book Company, ISBN 0-07-021799-8.

to compress a wide dynamic range input signal to give as output it's logarithmic equivalent. In some respects the name logarithmic amplifier is misleading and it would be better to consider the amplifier as a measurement device rather than an amplifier. For the ideal logarithmic amplifier when $I_i = I_r$, the output voltage $V_{out}(ideal) \Rightarrow 0$. In a practical logarithmic amplifier the current input terminals are effectively at virtual ground potential which allows the amplifier input signals to be derived from input voltages divided by scaling resistors of identical value. In this case $I_r = V_r/R$ and $I_i = V_i/R$, where V_r and V_i are the input signal voltages respectively, and R is the scaling resistance. Transforming from current inputs to voltage inputs gives equation (2).

$$V_{out}(ideal) = K_v \cdot \log \left(\frac{V_i}{V_r} \right) \quad (2)$$

To prevent the argument of the logarithmic amplifier from becoming negative the input signal I_i must always have the same polarity as reference signal I_r . The amplitude of the signal at terminal I must also be the same or greater than the signal at terminal R . This implies that logarithmic amplifiers are unipolar input devices. Similarly, to prevent the logarithmic amplifier output voltage from becoming excessively large and causing the output voltage to saturate³ the ratio of the two currents must be limited to a maximum value. In this context the dynamic range of a logarithmic amplifier is defined by equation (3).

$$\text{dynamic range} \simeq \log \left(\frac{I_i}{I_r} \right) \simeq \log \left(\frac{V_i}{V_r} \right) \quad (3)$$

In a real logarithmic amplifier I_r can be as low as 10 nA with the maximum allowed value of I_i around 10 mA, yielding a dynamic range of six decades. Integrated logarithmic amplifiers are available with dynamic ranges of five or six decades.

The practical logarithmic amplifier

The voltage output from a practical logarithmic amplifier⁴ differs from that given in equation (1) and can be written as

$$V_{out} = V_{out}(ideal) \pm TE \quad (4)$$

Where TE is called the total error. This can be represented by a function formed from the combination of errors in gain scale factor, input offset current, input bias

³Power supply voltages are often limited to ± 15 volts.

⁴See the manufacturers data sheets for (a) Burr Brown (from Texas Instruments) LOG100 and LOG101 amplifiers, and (b) Maxim MAX4206 amplifier.

current, output offset voltage and transfer function non-linearity. On adding the major contributions due to these errors equation (4) becomes equation (5).

$$V_{out} = K_v \cdot (1 \pm \Delta K_v) \cdot \log \left(\frac{I_i - I_{b1}}{I_r - I_{br}} \right) \pm 2 \cdot K_v \cdot N \cdot m \pm V_{osout} \quad (5)$$

In terms of voltage inputs equation (5) can be written as

$$V_{out} = K_v \cdot (1 \pm \Delta K_v) \cdot \log \left(\frac{\frac{V_i}{R} - I_{b1}}{\frac{V_r}{R} - I_{br}} \right) \pm 2 \cdot K_v \cdot N \cdot m \pm V_{osout} \quad (6)$$

Where ΔK_v is the scale error factor in percent, I_{b1} is the bias current at input I in amperes, I_{br} is the bias current at the reference input R in amperes, N is the log conformity error in percent, m is the number of decades over which N is specified, and V_{osout} is the output offset voltage. The log conformity error of a logarithmic amplifier is defined as the peak deviation from the best-fit straight line of V_{out} versus the $\log(I_i/I_r)$ curve expressed as a percentage of peak-to-peak full-scale. The other error parameters have their usual meaning. In general error parameters may be plus or minus in sign, leading to the \pm signs in the previous equations.

Logarithmic amplifier temperature effects

The error parameters introduced in the last section of this report are normally specified in manufacturers device data sheets as functions of temperature. As a first approximation parameter temperature dependence is usually limited to the simple linear functions of temperature given in equation (7).

$$\begin{aligned} \Delta K_v(Temp) &= \Delta K_v \cdot + \Delta K_v tc \cdot (Temp - Tnom) \\ I_{b1}(Temp) &= I_{b1} + I_{b1} tc \cdot (Temp - Tnom) \\ I_{br}(Temp) &= I_{br} + I_{br} tc \cdot (Temp - Tnom) \\ N(Temp) &= N + Ntc \cdot (Temp - Tnom) \\ V_{osout}(Temp) &= V_{osout} + V_{osout} tc \cdot (Temp - Tnom) \end{aligned} \quad (7)$$

Where $Temp$ is the circuit simulation temperature in Celsius, $Tnom$ is the device parameter measurement temperature in Celsius and $\Delta K_v tc$, $I_{b1} tc$, $I_{br} tc$, Ntc and $V_{osout} tc$ are first order linear temperature coefficients in percentage per degree Celsius or units per degree Celsius.

A compact macromodel for a logarithmic amplifier

Parameters

Name	Symbol	Description	Unit	Default*
Kv	K_v	Gain scale factor	V/decade	1.0
Dk	ΔK_v	Gain scale factor error	%	0.3 ⁺
Ib1	I_{b1}	Bias current at input I	A	5e-12
Ibr	I_{br}	Bias current at reference input R	A	5e-12
M	M	Number of decades over which N is specified		5
N	N	Log conformity error	%	0.1 ⁺
Vosout	V_{osout}	Output offset voltage	V	3e-3 ⁺
Rinp	R_{inp}	Amplifier input resistance	Ω	1e6
Fc	Fc	Amplifier voltage gain 2dB frequency	Hz	1e3
Ro	R_o	Amplifier output resistance	Ω	1e-3
Ntc	Ntc	Log conformity error temperature coefficient	%/Celsius	0.002
Vosouttc	$V_{osouttc}$	Output offset voltage temperature coefficient	V/Celsius	80e-6
Dktc	ΔK_vtc	Gain scale factor temperature coefficient	%/Celsius	0.03
Ib1tc	I_{b1tc}	Input I bias current temperature coefficient	A/Celsius	0.5e-12 ⁺⁺
Irtc	I_rtc	Input R bias current temperature coefficient	A/Celsius	0.5e-12 ⁺⁺
Tnom	T_{nom}	Parameter measurement temperature	Celsius	26.85

* The default parameters are for a typical integrated circuit logarithmic amplifier.

+ These parameters may be negative.

++ Typical bias current doubles for every eight to ten degrees temperature increase.

Verilog-A model code

```
// Qucs generic logarithmic amplifier model:
// This model can be used to construct working models for
// a range of different manufacturer's logarithmic amplifier ICs -
// for example the LOG100 and the MAX4206.
// All required parameters can be extracted directly from manufacturers data sheets.
// The structure and theoretical background to the logarithmic amplifier
// Verilog-a model are presented in the Qucs log_amp report.
//
// This is free software; you can redistribute it and/or modify
// it under the terms of the GNU General Public License as published by
// the Free Software Foundation; either version 2, or (at your option)
// any later version.
//
// Copyright (C), Mike Brinson, mbrin72043@yahoo.co.uk, January 2008.
//
```

```

'include "disciplines.vams"
'include "constants.vams"
//
module log_amp (P_I1, P_Ir, P_Vout);
inout P_I1, P_Ir;
inout P_Vout;
//
    electrical P_I1, P_Ir, P_Vout;
//
// Internal nodes
//
    electrical n3, n4;
//
'define attr(txt) (*txt*)
//
parameter real Kv = 1.0 from [-inf : inf]
    'attr(info="scale_factor" unit = "V/decade");
parameter real Dk = 0.3 from [-100 : 100]
    'attr(info="scale_factor_error" unit = "%");
parameter real Ib1 = 5e-12 from [-inf : inf]
    'attr(info="input_I1_bias_current" unit = "A");
parameter real Ibr = 5e-12 from [-inf : inf]
    'attr(info="input_reference_bias_current" unit = "A");
parameter real M = 5 from [1 : inf]
    'attr(info="number_of_decades");
parameter real N = 0.1 from [0 : 100]
    'attr(info="conformity_error" unit = "%");
parameter real Vosout = 3e-3 from [-inf : inf]
    'attr(info="output_offset_error" unit = "V");
parameter real Rinp = 1e6 from [1 : inf]
    'attr(info="amplifier_input_resistance" unit = "Ohm");
parameter real Fc = 1e3 from [1 : inf]
    'attr(info="amplifier_3dB_frequency" unit = "Hz");
parameter real Ro = 1e-3 from [1e-3 : inf]
    'attr(info="amplifier_output_resistance" unit = "Ohm");
parameter real Ntc = 0.002 from [-100 : 100]
    'attr(info="conformity_error_temperature_coefficient" unit = "%/Celsius");
parameter real Vosouttc = 80e-6 from [-inf : inf]
    'attr(info="offset_temperature_coefficient" unit = "V/Celsius");
parameter real Dktc = 0.03 from [-100 : 100]
    'attr(info="scale_factor_error_temperature_coefficient" unit = "%/Celsius");
parameter real Ib1tc = 0.5e-12 from [-inf : inf]
    'attr(info="input_I1_bias_current_temperature_coefficient" unit = "A/Celsius");
parameter real Ibrtc = 0.5e-12 from [-inf : inf]
    'attr(info="input_reference_bias_current_temperature_coefficient" unit = "A/Celsius");
parameter real Tnom = 26.85 from [-273 : inf]
    'attr(info="parameter_measurement_temperature" unit = "Celsius");
//
real R, Ix;
real V1, V2;
real Cc, PI;
real TempK, TnomK, Tdiff, NTemp, VosoutTemp, DkTemp, Ib1Temp, IbrTemp;
//
analog begin
//
// Constants
//
PI=3.14159265358979323846;
//
// Model equations
//
V1=V(P_I1);

```

```

V2=V(P_Ir)+1e-20;
R=Rinp+1e-6;
Cc=1/(2*PI*Fc);
//
TempK=$temperature;
TnomK=Tnom+273.15;
Tdiff=TempK-TnomK;
NTemp=N+Ntc*Tdiff;
VosoutTemp=Vosout+Vosouttc*Tdiff;
DkTemp=Dk+Dktc*Tdiff;
Ib1Temp=Ib1+Ib1tc*Tdiff;
IbrTemp=Ibr+Ibrtc*Tdiff;
//
if (V1 >= V2 ) Ix = Kv*(1+DkTemp/100)*log(((V1/R)-Ib1Temp)/((V2/R)-IbrTemp))+
(Kv*2*(NTemp/100)*M)+VosoutTemp ;
else Ix = 0.0;
//
// Circuit stages
//
// Input stage
//
I(P_I1) <+ V(P_I1)/R;
I(P_Ir) <+ V(P_Ir)/R;
//
// Log function stage
//
I(n3) <+ -Ix;
I(n3) <+ V(n3);
//
// Frequency compensation
//
I(n4) <+ -V(n3);
I(n4) <+ V(n4);
I(n4) <+ ddt(Cc*V(n4));
//
// Output stage
I(P_Vout) <+ -V(n4)/Ro;
I(P_Vout) <+ V(P_Vout)/Ro;
end
endmodule

```

The ADMS syntax is a subset of Verilog-A. Allowed language structures are outlined in a SYNTAX-SUPPORTED file which can be downloaded from <http://mot-adms.sourceforge.net>.

Basic logarithmic amplifier operation

The circuit shown in Fig. 1 demonstrates the operation of the logarithmic amplifier macromodel with the input signals set as voltages. Input scaling resistance R_{inp} is $10\text{k}\Omega$, the reference voltage is 100 uV DC (which is equivalent to $I_r = 10\text{ nA}$), and the input signal V_s is swept between 1 uV and 10 V DC . For input signals (V_2) less than V_1 the macromodel restricts the output voltage to zero volts, preventing signal ratios from being less than one. Figure 2 illustrates the logarithmic amplifier operating in current input mode. In Fig. 2 the input scaling resistors are set to 1Ω , causing the amplifier inputs to become effectively virtual earth points. Both

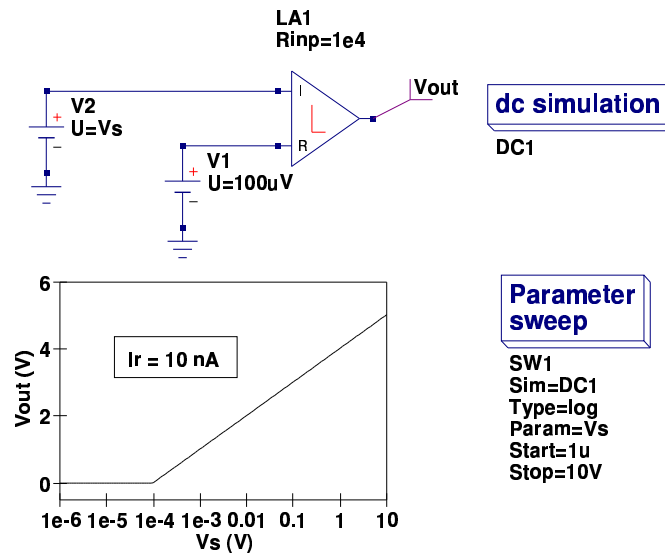

Figure 1: Qucs schematic for a basic voltage driven logarithmic amplifier and simulated DC transfer function

Fig. 1 and Fig. 2 illustrate the performance of a typical general purpose logarithmic amplifier over five signal decades, clearly showing the signal compression properties of the device.

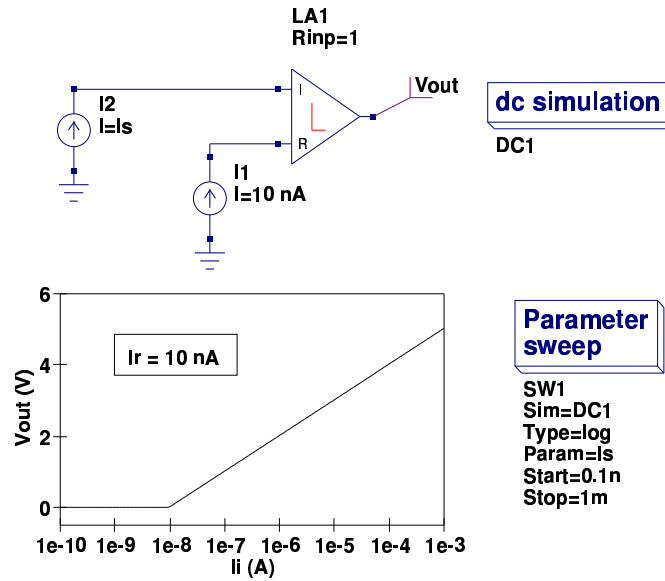

Figure 2: Qucs schematic for a basic current driven logarithmic amplifier and simulated DC transfer function

Functional description of the Verilog-A logarithmic amplifier macromodel

The macromodel of a general purpose logarithmic amplifier presented in previous sections simulates the following device characteristics:

- Input stage : Scaling resistances and DC bias currents.
- Gain stage : Logarithmic base ten transfer function over N decades with a single pole frequency response. Errors; gain scale and log conformity.
- Output stage : Resistance and DC offset voltage.
- Properties with temperature variation : gain scale, log conformity, bias currents and output offset voltage.

Input stage

The input stage is represented by the Verilog-A code listed in this subsection of the report. The voltages at input terminals P_{I1} and P_{Ir} are divided by scaling resistors R to give the required input currents. When R is small the input stage operates in current mode.

```

//
// Input stage
//
I(P_I1) <+ V(P_I1)/R;
I(P_Ir) <+ V(P_Ir)/R;

```

Gain stage

The gain stage is represented by the Verilog-A code listed in this subsection of the report. This part of the model determines the primary logarithmic amplifier transfer function, including logarithmic characteristics, frequency response, errors and temperature effects. An if-else statement is used to test if the log function argument is greater than one, setting the transfer function output to zero when the test fails. Both error terms and temperature factors have been included in the amplifier transfer function equation. Logarithmic amplifier transfer function frequency response is normally a complex function of input currents and an internal frequency compensation capacitance. Manufacturer's data sheets usually provide curves of frequency response for typical values of input current and compensation capacitance. Frequency effects are represented in the macromodel by a single pole response. The 3dB corner frequency being set by device parameter Fc . The default value of 3 kHz should be changed to suit the circuit operating conditions. Figure 3 illustrates a small signal test circuit which allows amplifier transfer function frequency response to be simulated.

```

//
// Constants
//
PI=3.14159265358979323846;
//
// Model equations
//
V1=V(P_I1);
V2=V(P_Ir)+1e-20;
R=Rinp+1e-6;
Cc=1/(2*PI*Fc);
//
TempK=$temperature;
TnomK=Tnom+273.15;
Tdiff=TempK-TnomK;
NTemp=N+Ntc*Tdiff;
VosoutTemp=Vosout+Vosouttc*Tdiff;
DkTemp=Dk+Dktc*Tdiff;
Ib1Temp=Ib1+Ib1tc*Tdiff;
IbrTemp=Ibr+Ibrtc*Tdiff;
//
if (V1 >= V2) Ix = Kv*(1+DkTemp/100)*log(((V1/R)-Ib1Temp)/((V2/R)-IbrTemp))+
(Kv*2*(NTemp/100)*M)+VosoutTemp ;
else Ix = 0.0;
..
..
..
//

```

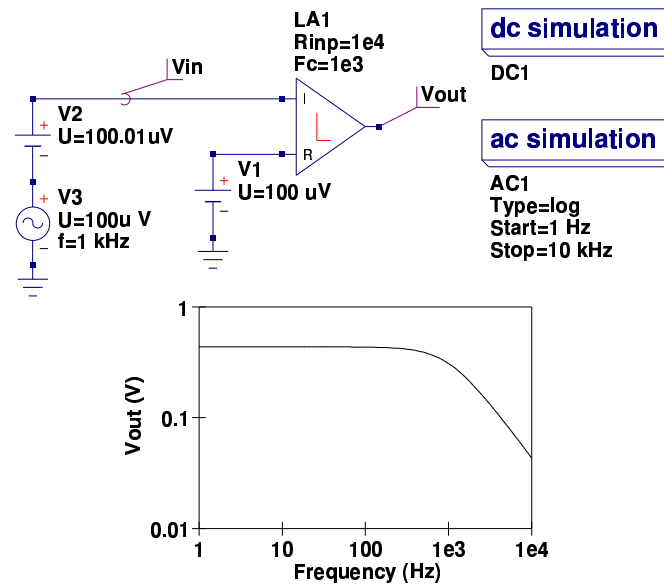

Figure 3: QuCS small signal AC test circuit and simulated transfer function

```
// Log function stage
//
I(n3) <+ -Ix;
I(n3) <+ V(n3);
//
// Frequency compensation
//
I(n4) <+ -V(n3);
I(n4) <+ V(n4);
I(n4) <+ ddt(Cc*V(n4));
```

Output stage

The output stage is represented by the Verilog-A code listed in this subsection of the report. This final section of the model introduces an output resistance R_0 . In a practical logarithmic amplifier this is often low in value.

```
//
// Output stage
I(P_Vout) <+ -V(n4)/Ro;
I(P_Vout) <+ V(P_Vout)/Ro;
```

Logarithmic amplifier large signal AC response

The circuit and waveforms presented in Fig. 4 illustrate how the large signal AC response of a logarithmic amplifier can be tested and displayed. In this circuit

a 100 Hz, 1.9 V peak sinewave signal, in series with a 2V battery, is applied to amplifier input I. Amplifier reference R has a 0.1V battery connected as the reference signal. As the logarithmic amplifier output signal is proportional to the log of the ratio of the input signals I/R , the shape of resulting output signal differs considerably from that of the excitation sinewave. When the peak of the input sinewave is 1.9 V the input ratio is 29 and when the negative peak reaches -1.9 V, the ratio is 1, yielding an output waveform with signal values between $\log(29)$ and 0. This example test circuit once again demonstrates the compression properties of logarithmic amplifiers.

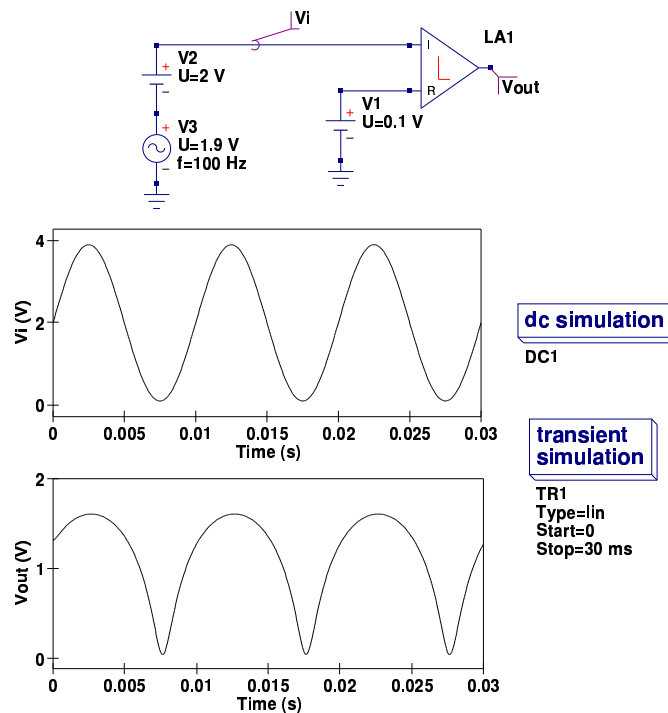

Figure 4: Qucs large signal logarithmic amplifier AC test circuit and simulated transient response

Logarithmic amplifier transfer function temperature variation

The test circuit shown in Fig. 5 introduces a double sweep which changes the amplifier circuit temperature from -110 to 100 Celsius, while simultaneously at each temperature, simulates, records and displays the amplifier transfer function. In this

very basic example of amplifier response to temperature changes all circuit dependent parameters are varied at the same time and no attempt is made to identify individual parameter contributions to the overall temperature dependency. From the results of this simple test the simulation waveforms indicate that the typical temperature coefficients only have minimal effect on circuit performance. Modern integrated logarithmic amplifiers are, in general, well temperature compensated, minimising the effects of temperature changes on circuit performance.

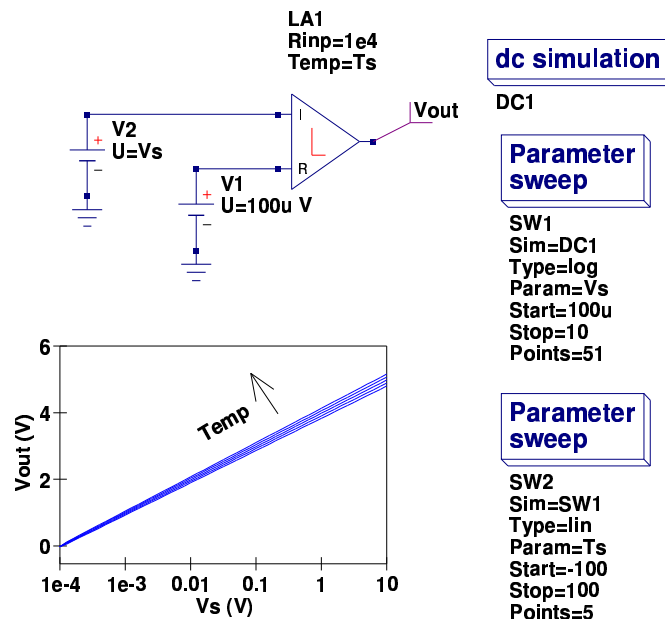

Figure 5: Qucs logarithmic amplifier transfer function test circuit and simulated temperature response

Logarithmic amplifier applications

In this section of this brief report two applications of the logarithmic amplifier are introduced. These examples are also used to demonstrate how Verilog-A modelled devices can be merged with other Qucs built-in components, subcircuits and equation defined devices. The application examples have been chosen to illustrate the power of Qucs modelling and simulation.

A simple signal multiplier

One of the most basic, and earliest, applications of the logarithmic amplifier was signal multiplication. Figure 6 shows a test circuit which includes two logarithmic

amplifiers, two voltage controlled voltages sources (these act as a voltage summer) and an antilog amplifier.

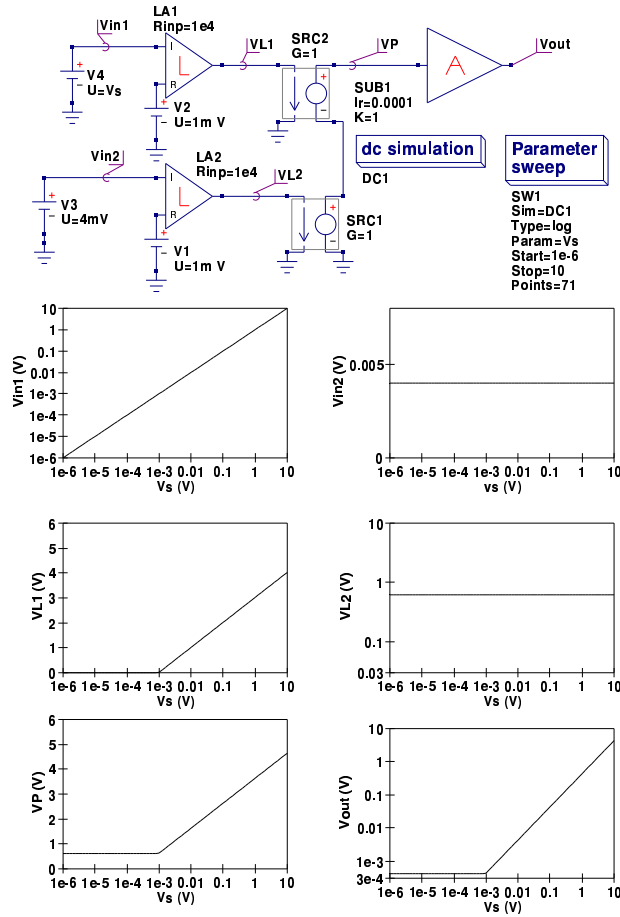

Figure 6: A simple electronic multiplier circuit and test waveforms

The circuit illustrated in Fig. 6 multiplies the ratios of the two sets of inputs. This is done by taking the log of each input ratio then adding the results and finally finding the antilog of the sum. The antilog of a voltage can be found using the circuit shown in Fig. 7. Parameters I_r and K are used to scale the output voltage. This must be within the power supply range of a practical device. In the example shown in Fig. 6 the second input ratio is constant at 4 and the first has a maximum value of $10/1e-3 = 1e4$, causing the output result to be $4e4$ which is way beyond the output voltage of a practical circuit. By setting $k=1$ and I_r to $1e-4$ the output voltage is scaled so that the maximum output becomes roughly 4 volts.

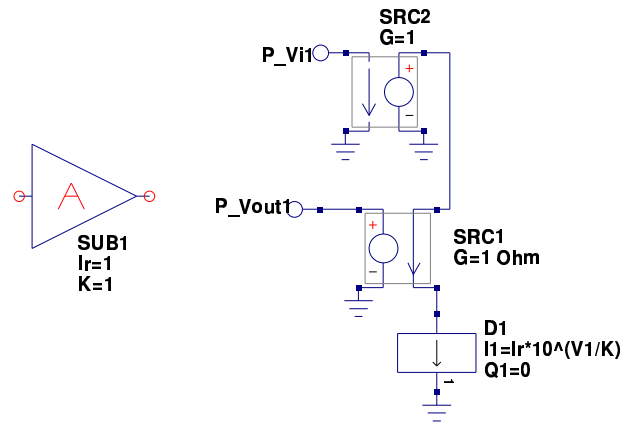

Figure 7: A simple antilog amplifier based on a single equation defined device: Controlled source SRC2 acts as a buffer and source SRC1 converts EDD current I1 to voltage

Light absorption measurements using photodiodes and a log amplifier

A number of years ago a colleague in Germany made the profound remark that the 20th century was the century of the electron and that the 21st century was likely to be the century of the photon. The current state of Qucs model development does to some extent reflect this thinking. At present the major modelling tasks involve extending the Qucs component/model range and the improvement of their individual performances. Looking through the current device/model list immediately confirms that it is dominated by electrical components and other domain devices, such as transducers, actuators and optical components, are non-existent. The logarithmic amplifier application reported here attempts to address this imbalance by providing some preliminary information on an area of modelling where significant work is likely to be done in the coming cycles of Qucs development, namely optical components. Optoelectronic devices, such as LEDs and photodiodes, are well established in the current electronics scene. Unfortunately, to my knowledge, Qucs lacks the models for such devices. The test circuit shown in Fig. 8 presents a basic arrangement for measuring the light absorption properties of liquids. This is a classical application of the logarithmic amplifier, working as a device that measures the ratio of two currents. These currents are generated by photodiodes. In Fig. 8 a light source shines on two photodiodes: directly on one and indirectly on the other. In the second case the light travels through a vessel containing a liquid which attenuates the light. The level of attenuation being dependent on the light absorption properties of the liquid. When little or no light is absorbed the logarithmic amplifier output is small. However, at high light absorption levels

the amplifier output is high. The circuit given in Fig. 8 works over six decades of light transmission coefficient. Moreover, it does not require the absolute values of the light intensities to be measured. The circuit output voltage is compressed to a range between 0 and 5 volts which is ideal for interfacing with a unipolar analogue-to-digital converter. Qucs cannot represent light signals directly. However, it is possible to use a voltage to represent the intensity of a light. Once one realises that the numerical value of light intensity can be represented by a voltage of the same numerical value then it also becomes possible to represent light signals paths by nets with specific voltage values. In Fig. 8 the light paths are represented by wires connecting the light source, the liquid vessel and the photodiodes. Models for the light absorbing liquid and the photodiodes are shown in Fig. 9.

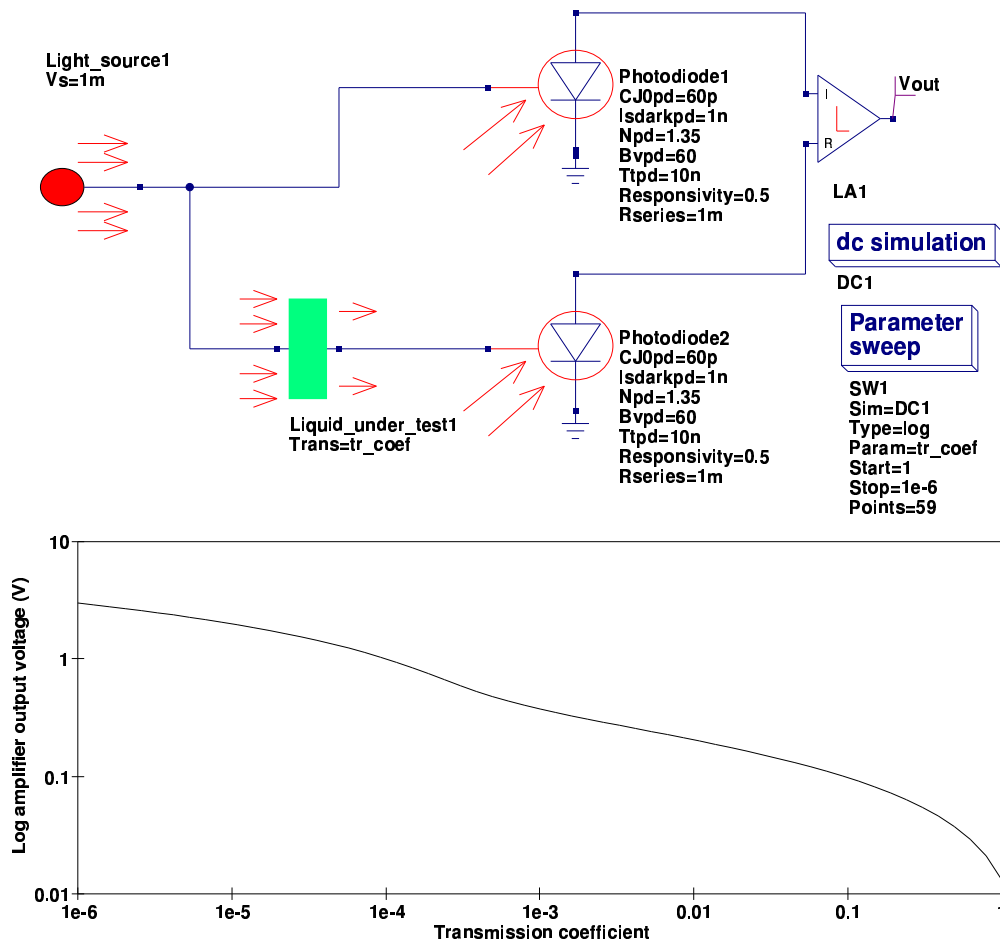

Figure 8: Light absorption measurements using photodiodes and a logarithmic amplifier

In Fig. 9 the light absorbing liquid is represented by a voltage controlled voltage

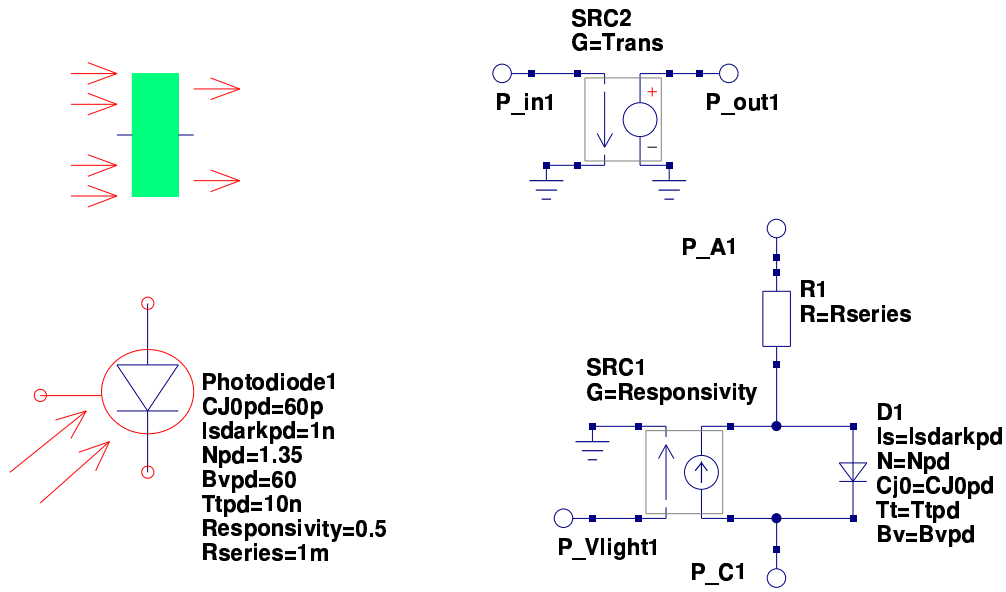

Figure 9: Experimental Qucs models for a light absorbing liquid and a photodiode

source where the source gain models the transmission coefficient: a gain of one implies 100% transmission and a gain of zero no light transmission at all. The photodiode model is much more complex. A voltage controlled current source in parallel with a diode forms the core of the model. The gain of the controlled source represents the responsivity of the diode. Responsivity is expressed in amperes per watt or as the photodiode current for a given input light power per unit area. As the current generated is also expressed as the current per unit area, effectively the area factor is eliminated. Equation (8) relates the photodiode current to the voltage at the light input terminal:

$$I_d = \text{Responsivity} \cdot V(PVlight) \quad (8)$$

Responsivity is a function of the light wavelength and is around 0.5 to 0.6 for wavelengths of 900nm. It is roughly 0.3 for blue wavelengths and drops to 0.2 in the ultraviolet region of the spectrum. With no illumination falling on a photodiode the resulting diode current is small, being called the device dark current. It ranges from tens of pA for ultraviolet detecting photodiodes to several μA for low cost silicon diodes. Typical values for R_{series} are in the range 1m to 20m Ω . The other parameters are similar to those representing standard semiconductor diodes but with values specifically chosen to represent the properties of photodiodes.

End note

These notes summarise a basic technique for modelling logarithmic amplifiers using Verilog-A. Verilog-A is primarily intended for modelling compact semiconductor devices. However, as this report demonstrates it can be equally employed for macromodelling of integrated circuits and circuits in general. The Qucs C++ code for the modular operational amplifier model, generated by ADMS, can be found in the Qucs release archives at <http://qucs.sourceforge.net/download.html>. The procedure undertaken to convert the Verilog-A code into C++ for compilation and linking with Qucs closely followed that described by Stefan Jahn and H el ene Parruitte. Although it takes more work to construct models using ADMS the effort is worthwhile because the finished models are very efficient in terms of memory usage and have significantly reduced run times. It is worth noting that Verilog-A based models can be combined with other forms of Qucs model, forming a powerful combination that extends Qucs simulation capabilities. Once again a special thanks to Stefan Jahn for all his help and encouragement over the period that I have been developing the Verilog-A logarithmic amplifier macromodel, writing this report and testing the examples it includes.